



Dell™ PowerEdge™ 2400 Systems

**INSTALLATION AND
TROUBLESHOOTING
GUIDE**

**Information in this document is subject to change without notice.
© 1999 Dell Computer Corporation. All rights reserved.**

Reproduction in any manner whatsoever without the written permission of Dell Computer Corporation is strictly forbidden.

Trademarks used in this text: *Dell*, the *DELL* logo, *PowerEdge*, *Dimension*, *Inspiron*, *OptiPlex*, *Latitude*, *Dell OpenManage*, and *DellWare* are trademarks of Dell Computer Corporation; *Microsoft*, *MS-DOS*, *Windows*, and *Windows NT* are registered trademarks of Microsoft Corporation; *MMX* is a trademark of Intel Corporation; *OS/2* is a registered trademark of International Business Machines Corporation; *VESA* is a registered trademark of Video Electronics Standards Association.

Other trademarks and trade names may be used in this document to refer to either the entities claiming the marks and names or their products. Dell Computer Corporation disclaims any proprietary interest in trademarks and trade names other than its own

October 1999 P/N 9437P Rev. A01

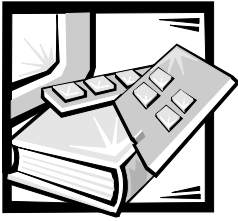

Safety Instructions

Use the following safety guidelines to ensure your own personal safety and to help protect your computer or storage system from potential damage.

Notes, Notices, Cautions, and Warnings

Throughout this guide, blocks of text may be accompanied by an icon and printed in bold type or in italic type. These blocks are notes, notices, cautions, and warnings, and they are used as follows:



NOTE: A NOTE indicates important information that helps you make better use of your computer system.

NOTICE: A NOTICE indicates either potential damage to hardware or loss of data and tells you how to avoid the problem.



CAUTION: A CAUTION indicates a potentially hazardous situation which, if not avoided, may result in minor or moderate injury.



WARNING: A WARNING indicates a potentially hazardous situation which, if not avoided, could result in death or serious bodily injury

Safety Caution and Warnings

Observe the following caution and warnings while servicing this system:



CAUTION: There is a danger of a new battery exploding if it is incorrectly installed. Replace the battery only with the same or equivalent type recommended by the manufacturer. Discard used batteries according to the manufacturer's instructions.



WARNING: This system may have more than one power supply cable. To reduce the risk of electrical shock, disconnect all power supply cables before servicing the system.

DŮLEŽITÉ UPOZORNĚNÍ: Tento systém může mít více napájecích kabelů. Ke snížení rizika úrazu elektrickým proudem je nutné, aby školený servisní technik před prováděním servisu systému odpojil všechny napájecí kabely.

ADVARSEL: Dette system kan have mere end et strømforlyningskabel. For at reducere risikoen for elektrisk stød, bør en professionel servicetekniker frakoble alle strømforlyningskabler, før systemet serviceres.

VAROITUS: Tässä järjesteImässä voi olla useampi kuin yksi virtajohto. Sähköiskuvaaran pienentämiseksi ammattitaitoisen huoltohenkilön on irrotettava kaikki virtajohtot ennen järjesteImän huoltamista.

Í ĞÁÁÓÍ ĞÁÆÁÁÍ ĒÁ: Ááí í áy ñèñòáì à ì í æáò èì áòù í áñéí èúéí èáááééé yéáéòðí í èòáí èý. Áí èçááæáí èá yéáéòðè-áñéí áí óááòá èááéèèèèèðí ááí í Úé óáóí èè áí èæáí í ðèèþ-èòù áñá èáááéè yéáéòðí í èòáí èý í ðáæáá, áì í ðèñóí èòù è í áñéóæéááí èþ ñèñòáì Û.

OSTRZE^{ENIE}: System ten mo¿e mieæ wiêcej ni¿ jeden kabel zasilania. Aby zmniejszæ ryzyko pora¿enia pr¹dem, przed napraw¹ lub konserwacj¹ systemu wszystkie kable zasilania powinny byæ od³¹czone przez przeszkolonego technika obs³ugi.

ADVARSEL! Det er mulig at dette systemet har mer enn én strømlledning. Unngå fare for stød: En erfaren servicetekniker må koble fra alle strømlledninger før det utføres service på systemet.

WARNING: Detta system kan ha flera nätkablar. En behörig servicetekniker måste koppla loss alla nätkablar innan service utförs för att minska risken för elektriska stötar.



Additional Safety Precautions

To reduce the risk of bodily injury, electrical shock, fire, and damage to the equipment, observe the following precautions.

General Precautions

Observe the following general precautions for using and working with your system:

- Observe and follow service markings. Do not service any Dell product except as explained in your Dell system documentation. Opening or removing covers that are marked with the triangular symbol with a lightning bolt may expose you to electrical shock. Components inside these compartments should be serviced only by a Dell authorized service technician.
- If any of the following conditions occur, unplug the product from the electrical outlet and replace the part or contact your Dell authorized service provider:
 - The power cable, extension cord, or plug is damaged.
 - An object has fallen into the product.
 - The product has been exposed to water.
 - The product has been dropped or damaged.

- The product does not operate correctly when you follow the operating instructions.
- Keep your system components away from radiators and heat sources. Also, do not block cooling vents.
- Do not spill food or liquids on your system components, and never operate the product in a wet environment. If the computer gets wet, see the appropriate section in your troubleshooting guide or contact a Dell-authorized service provider.
- Do not push any objects into the openings of your system components. Doing so can cause fire or electric shock by shorting out interior components.
- Use the product only with Dell products or other Dell-approved equipment.
- Allow the product to cool before removing covers or touching internal components.
- Use the correct external power source. Operate the product only from the type of power source indicated on the electrical ratings label. If you are not sure of the type of power source required, consult your Dell service provider or local power company.
- To help avoid damaging your system components, be sure the voltage selection switch (if provided) on the power supply is set to match the power available at your location:
 - 115 volts (V)/60 hertz (Hz) in most of North and South America and some Far Eastern countries such as South Korea and Taiwan
 - 100 V/50 Hz in eastern Japan and 100 V/60 Hz in western Japan
 - 230 V/50 Hz in most of Europe, the Middle East, and the Far East

Also be sure that your monitor and attached peripherals are electrically rated to operate with the power available in your location.

- Use only approved power cable(s). If you have not been provided with a power cable for your computer or storage system or for any AC-powered option intended for your system, purchase a power cable that is approved for use in your country. The power cable must be rated for the product and for the voltage and current marked on the product's electrical ratings label. The voltage and current rating of the cable should be greater than the ratings marked on the product.
- To help prevent electric shock, plug the system components and peripheral power cables into properly grounded electrical outlets. These cables are equipped with three-prong plugs to help ensure proper grounding. Do not use adapter plugs or remove the grounding prong from a cable. If you must use an extension cord, use a three-wire cord with properly grounded plugs.
- Observe extension cord and power strip ratings. Make sure that the total ampere rating of all products plugged into the extension cord or power strip does not exceed 80 percent of the extension cord or power strip ampere ratings limit.
- Do not use appliance/voltage converters or kits sold for appliances with your Dell product.

- To help protect your system components from sudden, transient increases and decreases in electrical power, use a surge suppressor, line conditioner, or uninterruptible power supply (UPS).
- Position cables and power cords carefully; route cables and the power cord and plug so that they cannot be stepped on or tripped over. Be sure that nothing rests on your system components' cables or power cord.
- Do not modify power cables or plugs. Consult a licensed electrician or your power company for site modifications. Always follow your local/national wiring rules.
- To help avoid possible damage to the system board, wait 5 seconds after turning off the system before removing a component from the system board or disconnecting a peripheral device from the computer.
- Handle batteries carefully. Do not disassemble, crush, puncture, short external contacts, dispose of in fire or water, or expose batteries to temperatures higher than 60 degrees Celsius (140 degrees Fahrenheit). Do not attempt to open or service batteries; replace batteries only with batteries designated for the product.
- Turn down the volume before using headphones or other audio devices.

Precautions for Server and Storage Systems

Follow the additional safety guidelines for your system:

- Unless your installation and/or troubleshooting documentation specifically allows it, do not remove enclosure covers, attempt to override the safety interlocks, or access any components inside the system. Depending on your system, installation and repairs may be done only by individuals who are qualified to service your computer or storage system equipment and trained to deal with products capable of producing hazardous energy levels.
- When connecting or disconnecting power to hot-pluggable power supplies, if offered with your Dell product, observe the following guidelines:
 - Install the power supply before connecting the power cable to the power supply.
 - Unplug the power cable before removing the power supply.
 - If the system has multiple sources of power, disconnect power from the system by unplugging *all* power cables from the power supplies.
- Move products with care; ensure that all casters and/or stabilizers are firmly connected to the computer or storage system. Avoid sudden stops and uneven surfaces.

Precautions for Rack-Mountable Products

Observe the following precautions for rack stability and safety. Also refer to the rack installation documentation accompanying the system and the rack for specific warning and/or caution statements and procedures.



WARNING: Installing Dell system components in a Dell rack without the front and side stabilizers installed could cause the rack to tip over, potentially resulting in bodily injury under certain circumstances. Therefore, always install the stabilizers before installing components in the rack.

After installing system components in a rack, never pull more than one component out of the rack on its slide assemblies at one time. The weight of more than one extended component could cause the rack to tip over and injure someone.



NOTE: Dell's server and storage systems are certified as components for use in Dell's rack cabinet using the Dell customer rack kit. The final installation of Dell systems and rack kits in any other brand of rack cabinet has not been approved by any safety agencies. It is the customer's responsibility to have the final combination of Dell systems and rack kits for use in other brands of rack cabinets evaluated for suitability by a certified safety agency.

- System rack kits are intended to be installed in a Dell rack by trained service technicians. If you install the kit in any other rack, be sure that the rack meets the specifications of a Dell rack.
- Do not move large racks by yourself. Due to the height and weight of the rack, Dell recommends a minimum of two people to accomplish this task.
- Before working on the rack, make sure that the stabilizers are secure to the rack, extend to the floor, and that the full weight of the rack rests on the floor. Install front and side stabilizers on a single rack or front stabilizers for joined multiple racks before working on the rack.
- Always load the rack from the bottom up, and load the heaviest item in the rack first.
- Make sure that the rack is level and stable before extending a component from the rack.
- Extend only one component at a time from the rack.
- Use caution when pressing the component rail release latches and sliding a component into or out of a rack; the slide rails can pinch your fingers.
- After a component is inserted into the rack, carefully extend the rail into a locking position, and then slide the component into the rack.
- Do not overload the AC supply branch circuit that provides power to the rack. The total rack load should not exceed 80 percent of the branch circuit rating.
- Ensure that proper airflow is provided to components in the rack.
- Do not step on or stand on any system/component when servicing other systems/components in a rack.

Precautions for Products With Modems, Telecommunications, or Local Area Network Options

Observe the following guidelines when working with options:

- Do not connect or use a modem or telephone during a lightning storm. There may be a risk of electrical shock from lightning.
- Never connect or use a modem or telephone in a wet environment.
- Do not plug a modem or telephone cable into the network interface controller (NIC) receptacle.
- Disconnect the modem cable before opening a product enclosure, touching or installing internal components, or touching an uninsulated modem cable or jack.
- Do not use a telephone line to report a gas leak while you are in the vicinity of the leak.

Precautions for Products With Laser Devices

Observe the following precautions for laser devices:

- Do not open any panels, operate controls, make adjustments, or perform procedures on a laser device other than those specified in the product's documentation.
- Only authorized service technicians should repair laser devices.

When Working Inside Your Computer

Before you remove the computer covers, perform the following steps in the sequence indicated.

NOTICE: Some Dell systems can be serviced only by trained service technicians because of high voltages and energy hazards. Do not attempt to service the computer system yourself, except as explained in this guide and elsewhere in Dell documentation. Always follow installation and service instructions closely.

NOTICE: To help avoid possible damage to the system board, wait 5 seconds after turning off the system before removing a component from the system board or disconnecting a peripheral device from the computer.

1. Turn off your computer and any peripherals.
2. Ground yourself by touching an unpainted metal surface on the chassis, such as the metal around the card-slot openings at the back of the computer, before touching anything inside your computer.

While you work, periodically touch an unpainted metal surface on the computer chassis to dissipate any static electricity that might harm internal components.

3. Disconnect your computer and peripherals from their power sources. Also, disconnect any telephone or telecommunication lines from the computer.

Doing so reduces the potential for personal injury or shock.

In addition, take note of these safety guidelines when appropriate:

- When you disconnect a cable, pull on its connector or on its strain-relief loop, not on the cable itself. Some cables have a connector with locking tabs; if you are disconnecting this type of cable, press in on the locking tabs before disconnecting the cable. As you pull connectors apart, keep them evenly aligned to avoid bending any connector pins. Also, before you connect a cable, make sure that both connectors are correctly oriented and aligned.
- Handle components and cards with care. Don't touch the components or contacts on a card. Hold a card by its edges or by its metal mounting bracket. Hold a component such as a microprocessor chip by its edges, not by its pins.



CAUTION: There is a danger of a new battery exploding if it is incorrectly installed. Replace the battery only with the same or equivalent type recommended by the manufacturer. Discard used batteries according to the manufacturer's instructions.

Protecting Against Electrostatic Discharge

Static electricity can harm delicate components inside your computer. To prevent static damage, discharge static electricity from your body before you touch any of your computer's electronic components, such as the microprocessor. You can do so by touching an unpainted metal surface on the computer chassis.

As you continue to work inside the computer, periodically touch an unpainted metal surface to remove any static charge your body may have accumulated.

You can also take the following steps to prevent damage from electrostatic discharge (ESD):

- When unpacking a static-sensitive component from its shipping carton, do not remove the component from the antistatic packing material until you are ready to install the component in your computer. Just before unwrapping the antistatic packaging, be sure to discharge static electricity from your body.
- When transporting a sensitive component, first place it in an antistatic container or packaging.
- Handle all sensitive components in a static-safe area. If possible, use antistatic floor pads and workbench pads.

The following notice may appear throughout this document to remind you of these precautions:

NOTICE: See "Protecting Against Electrostatic Discharge" in the safety instructions.

Ergonomic Computing Habits



CAUTION: Improper or prolonged keyboard use may result in injury.



CAUTION: Viewing the monitor screen for extended periods of time may result in eye strain.

For comfort and efficiency, observe the following ergonomic guidelines when you set up and use your computer system:

- Position your system so that the monitor and keyboard are directly in front of you as you work. Special shelves are available (from Dell and other sources) to help you correctly position your keyboard.
- Set the monitor at a comfortable viewing distance (usually 510 to 610 millimeters [20 to 24 inches] from your eyes).
- Make sure that the monitor screen is at eye level or slightly lower when you sit in front of the monitor.
- Adjust the tilt of the monitor, its contrast and brightness settings, and the lighting around you (such as overhead lights, desk lamps, and the curtains or blinds on nearby windows) to minimize reflections and glare on the monitor screen.
- Use a chair that provides good lower back support.
- Keep your forearms horizontal with your wrists in a neutral, comfortable position while you use the keyboard or mouse.
- Always leave space to rest your hands while you use the keyboard or mouse.
- Let your upper arms hang naturally at your sides.
- Sit erect, with your feet resting on the floor and your thighs level.
- When sitting, make sure the weight of your legs is on your feet and not on the front of your chair seat. Adjust your chair's height or use a footrest, if necessary, to maintain proper posture.
- Vary your work activities. Try to organize your work so that you do not have to type for extended periods of time. When you stop typing, try to do things that use both hands.



-
- 1 Monitor screen at or below eye level
 - 2 Wrists relaxed and flat
 - 3 Arms at desk level
 - 4 Feet flat on the floor
 - 5 Monitor and keyboard positioned directly in front of user
-

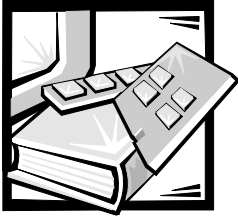

Preface

About This Guide

This guide is intended for anyone who wants to upgrade or troubleshoot a Dell PowerEdge 2400 computer system. Before calling Dell for technical assistance, follow the recommended procedure(s) in this guide to solve most hardware and software problems yourself. The sections are summarized as follows:

- Chapter 1, "Introduction" — Overview of the system's service features.
- Chapter 2, "Checking the Basics" — Initial checks and procedures used to solve basic system problems and information on more detailed troubleshooting procedures to solve more complex problems.
- Chapter 3, "Messages and Codes" — System messages, system beep codes, warning messages, diagnostics messages, alert log messages, and small computer system interface (SCSI) hard-disk drive indicator codes.
- Chapter 4, "Finding Software Solutions" — Software-related problems or problems after testing the computer's hardware.
- Chapter 5, "Running the Dell Diagnostics" — Hardware-related problems.
- Chapter 6, "Checking the Equipment," and Chapter 7, "Checking Inside the Computer" — Troubleshooting procedures for equipment connected to the input/output (I/O) panel of the computer and components inside the computer, respectively. "Checking Inside the Computer" also provides information on removing the computer covers.
- Chapter 8, "Installing System Board Options," Chapter 9, "Installing Drives in the External Bays," Chapter 10, "Installing Hard-Disk Drives," and Appendix B, "Installing Redundant Power Supplies" — Installation or removal of system components, such as dual in-line memory modules (DIMMs), microprocessors, expansion cards, and SCSI devices.
- Chapter 11, "Getting Help" — Help tools Dell provides to assist with computer problems and explanations on how and when to call Dell for technical assistance. Also includes a Diagnostics Checklist that you can copy and fill out as you perform the troubleshooting procedures. If you need to call Dell for technical assistance, use the completed checklist to tell the Dell technical support representative what procedures you performed to better help the representative give you assistance. If you must return a piece of hardware to Dell, include a filled-out checklist.

- Appendix A, "Jumpers, Switches, and Connectors" — Jumper or switch settings to change when troubleshooting the system or adding internal options.
- "Abbreviations and Acronyms" — Abbreviations and acronyms used throughout this guide and in other Dell documentation for the system.

Other Documentation You May Need

In addition to this *Installation and Troubleshooting Guide*, the following documentation is included with your system:

- The *Dell PowerEdge 2400 Systems User's Guide*, which describes system features and technical specifications, device drivers, the System Setup program, Resource Configuration Utility, and the System Setup Utility.
- The HP OpenView Network Node Manager Special Edition *User's Guide*, which describes the features, requirements, installation, and basic operation of the server management software. Refer to the software's online help for information about the alert messages issued by the software.

You may also have one or more of the following documents.



NOTE: Documentation updates are sometimes included with the system to describe changes to the system or software. Always read these updates before consulting any other documentation because the updates often contain information that supersedes the information in the other documents.

- Operating system documentation is included with the system if you ordered the operating system software from Dell. This documentation describes how to install (if necessary), configure, and use the operating system software.
- Documentation is included with any options you purchase separately from the system. This documentation includes information that you need to configure and install these options in your Dell computer.
- Technical information files—sometimes called "readme" files—may be installed on the hard-disk drive to provide last-minute updates about technical changes to the system or advanced technical reference material intended for experienced users or technicians.

Typographical Conventions

The following list defines (where appropriate) and illustrates typographical conventions used as visual cues for specific elements of text throughout this document:

- *Interface components* are window titles, button and icon names, menu names and selections, and other options that appear on the monitor screen or display. They are presented in bold.

Example: Click **OK**.

- *Keycaps* are labels that appear on the keys on a keyboard. They are enclosed in angle brackets.
Example: <Enter>
 - *Key combinations* are series of keys to be pressed simultaneously (unless otherwise indicated) to perform a single function.
Example: <Ctrl><Alt><Enter>
 - *Commands* presented in lowercase bold are for reference purposes only and are not intended to be typed when referenced.
Example: "Use the **format** command to"
- In contrast, commands presented in the Courier New font are part of an instruction and intended to be typed.
- Example: "Type `format a:` to format the diskette in drive A."
- *Filenames* and *directory names* are presented in lowercase bold.
Examples: **autoexec.bat** and **c:\windows**
 - *Syntax lines* consist of a command and all its possible parameters. Commands are presented in lowercase bold; variable parameters (those for which you substitute a value) are presented in lowercase italics; constant parameters are presented in lowercase bold. The brackets indicate items that are optional.
Example: **del** [*drive:*] [*path*] *filename* [**/p**]
 - *Command lines* consist of a command and may include one or more of the command's possible parameters. Command lines are presented in the Courier New font.
Example: `del c:\myfile.doc`
 - *Screen text* is a message or text that you are instructed to type as part of a command (referred to as a *command line*). Screen text is presented in the Courier New font.
Example: The following message appears on your screen:

`No boot device available`
Example: "Type `md c:\programs` and press <Enter>."
 - *Variables* are placeholders for which you substitute a value. They are presented in italics.
Example: DIMM_*x* (where *x* represents the DIMM socket designation).

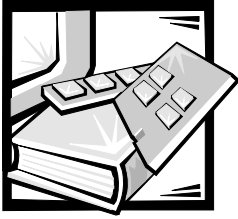

Contents

Chapter 1	Introduction	1-1
Chapter 2	Checking the Basics	2-1
	Backing Up Files	2-1
	Basic Checks	2-1
	Checking Connections and Switches	2-2
	Look and Listen	2-6
	The System Setup Program	2-7
	The Resource Configuration Utility	2-8
Chapter 3	Messages and Codes	3-1
	System Messages	3-1
	System Beep Codes	3-9
	Warning Messages	3-13
	Diagnostics Messages	3-14
	Alert Log Messages From the Dell OpenManage HIP Application	3-14
	SCSI Hard-Disk Drive Indicator Codes	3-16
Chapter 4	Finding Software Solutions	4-1
	Installing and Configuring Software	4-1
	Using Software	4-2
	Error Messages	4-2
	Input Errors	4-2
	Program Conflicts	4-2
	Avoiding Interrupt Assignment Conflicts	4-2

Chapter 5	Running the Dell™ Diagnostics	5-1
	Features of the Dell Diagnostics	5-1
	When to Use the Dell Diagnostics	5-1
	Starting the Dell Diagnostics	5-2
	How to Use the Dell Diagnostics	5-3
	How to Use the Device Groups Menu	5-3
	Device Groups Menu Options	5-3
	Run Tests	5-4
	Devices	5-4
	Select	5-5
	Config.	5-5
	Error Messages	5-5
Chapter 6	Checking the Equipment	6-1
	Troubleshooting the Monitor	6-1
	Troubleshooting the Keyboard	6-2
	Troubleshooting the Basic I/O Functions	6-3
	Troubleshooting a Parallel Printer	6-4
	Troubleshooting a Serial I/O Device	6-5
	Troubleshooting a USB Device	6-6
Chapter 7	Checking Inside the Computer	7-1
	Safety First—For You and Your Computer	7-1
	Removing and Replacing the Computer Covers	7-2
	Removing the Computer Covers	7-2
	Replacing the Computer Covers	7-5
	Removing and Replacing the Cooling Shroud	7-5
	Removing the Cooling Shroud	7-5
	Replacing the Cooling Shroud	7-7
	Inside the Chassis	7-7
	Responding to a Dell OpenManage Hardware Instrumentation Package Alert Message	7-8
	Troubleshooting a Wet Computer	7-8
	Troubleshooting a Damaged Computer	7-9
	Troubleshooting the Battery	7-10
	Troubleshooting Redundant Power Supplies	7-11
	Removing and Replacing a Power Supply	7-12
	Troubleshooting a Cooling Fan	7-13
	Troubleshooting Expansion Cards	7-14
	Troubleshooting System Memory	7-16
	Troubleshooting the Video Subsystem	7-18
	Troubleshooting the System Board	7-19

Troubleshooting the Diskette Drive Subsystem	7-21
Troubleshooting a SCSI Tape Drive	7-23
Troubleshooting SCSI Hard-Disk Drives	7-26
Troubleshooting a RAID Controller	7-28
Troubleshooting an Integrated PERC 2/Si RAID Controller	7-28
Troubleshooting a PERC 2 Controller Card	7-29

Chapter 8 *Installing System Board Options 8-1*

Expansion Cards	8-3
Choosing an Expansion Slot	8-4
Installing an Expansion Card	8-5
Removing an Expansion Card	8-7
Adding Memory	8-8
Memory Upgrade Kits	8-8
DIMM Installation Guidelines	8-8
Performing a Memory Upgrade	8-9
Installing DIMMs	8-10
Removing DIMMs	8-11
Upgrading the Microprocessor or Installing a Secondary Microprocessor	8-12
Removing a Terminator Card	8-12
Installing a Terminator Card	8-13
Removing the SEC Cartridge and Heat Sink Assembly	8-14
Replacing the SEC Cartridge and Heat Sink Assembly	8-15
Activating the Integrated RAID Controller	8-17
Replacing the Battery	8-18

Chapter 9 *Installing Drives in the External Bays. 9-1*

Before You Begin	9-3
Removing and Replacing Front-Panel Inserts	9-3
Removing a Plastic Insert	9-3
Removing a Metal Insert	9-3
Connecting the Drive	9-4
Interface Cables	9-4
DC Power Cables	9-4
SCSI Configuration Information	9-4
SCSI ID Numbers	9-4
Device Termination	9-5
Installing a SCSI Device	9-5
Installing a Tape Drive That Uses a Controller Card	9-6
Connecting an External Tape Drive	9-7

Chapter 10	Installing Hard-Disk Drives.	10-1
	Preparing SCSI Hard-Disk Drives for Installation	10-2
	SCSI Hard-Disk Drive Configuration	10-3
	Partitioning and Formatting SCSI Hard-Disk Drives	10-3
	Installing and Removing SCSI Hard-Disk Drives	10-3
	Installing a SCSI Hard-Disk Drive	10-3
	Removing a SCSI Hard-Disk Drive	10-5
	Installing a Dell PowerEdge Expandable RAID Controller Host Adapter Card	10-5
	Installing a SCSI Backplane Board	10-6
	Configuring the Boot Device	10-9
Chapter 11	Getting Help	11-1
	Technical Assistance	11-1
	Help Tools	11-1
	World Wide Web on the Internet	11-2
	AutoTech Service	11-3
	TechFax Service	11-3
	TechConnect BBS	11-3
	Automated Order-Status System	11-3
	Technical Support Service	11-3
	Problems With Your Order	11-4
	Product Information	11-4
	Returning Items for Warranty Repair or Credit	11-4
	Before You Call	11-5
	Diagnostics Checklist	11-5
	Dell Contact Numbers	11-7
	International Dialing Codes	11-8
	11-19
Appendix A	Jumpers, Switches, and Connectors	A-1
	Jumpers and Switches—A General Explanation	A-1
	Jumpers	A-1
	Switches	A-2
	System Board Jumpers	A-2
	System Board Labels	A-4
	SCSI Backplane Boards	A-5
	Disabling a Forgotten Password	A-6

Appendix B *Installing Redundant Power Supplies B-1*
 Installing the PSDB B-1
 Installing the Dual Power Supplies B-6
Abbreviations and Acronyms

Table 2-1.	Boot Routine Indications	2-6
Table 3-1.	System Messages	3-2
Table 3-2.	System Beep Codes	3-10
Table 3-3.	Dell HIP Application Alert Log Messages	3-14
Table 3-4.	SCSI Hard-Disk Drive Indicator Patterns	3-17
Table 4-1.	IRQ Line Assignment Defaults	4-3
Table 5-1.	Devices Options	5-4
Table 5-2.	Parameters Options	5-5
Table 8-1.	Sample DIMM Configurations	8-9
Table 11-1.	International Dialing Codes	11-8
Table 11-2.	Dell Contact Numbers	11-9
Table A-1.	System-Board Jumper Settings	A-3
Table A-2.	System Board Connectors and Sockets	A-4

Figure 2-1.	Back-Panel Features	2-3
Figure 2-2.	Front-Panel Features	2-4
Figure 3-1.	Hard-Disk Drive Indicators 3-16	
Figure 7-1.	Opening the Front Bezel	7-3
Figure 7-2.	Removing the Computer Covers	7-4
Figure 7-3.	Removing the Cooling Shroud	7-6
Figure 7-4.	Inside the System (Right-Side View)	7-7
Figure 7-5.	Power Supply Features	7-12
Figure 8-1.	System Board Features	8-2
Figure 8-2.	Expansion-Card Connectors	8-4
Figure 8-3.	Installing an Expansion Card	8-6
Figure 8-4.	DIMM Sockets	8-8
Figure 8-5.	Installing a DIMM	8-10
Figure 8-6.	Removing a DIMM	8-11
Figure 8-7.	Removing a Terminator Card	8-13
Figure 8-8.	Removing an SEC Cartridge and Heat Sink	8-15
Figure 8-9.	Installing an SEC Cartridge and Heat Sink Assembly	8-16
Figure 8-10.	Installing the RAID Hardware Key	8-17
Figure 8-11.	Installing the Battery	8-19
Figure 9-1.	External Drive Bay Hardware	9-2
Figure 10-1.	Hard-Disk Drive Hardware	10-2
Figure 10-2.	Installing a SCSI Hard-Disk Drive Carrier	10-4
Figure 10-3.	Installing a SCSI Backplane Board	10-8
Figure 10-4.	SCSI Backplane Board	10-9
Figure 11-1.	Diagnostics Checklist	11-6
Figure A-1.	System Board Jumpers	A-3
Figure A-2.	Connectors on the SCSI Backplane Boards	A-5
Figure B-1.	Removing the Top Cover	B-2
Figure B-2.	Removing the Power Supply	B-3
Figure B-3.	Installing the PSDB and Dual Power Supplies	B-4
Figure B-4.	Features on the PSDB	B-5



CHAPTER 1

Introduction

Dell™ PowerEdge™ 2400 computer systems are high-speed servers that offer significant service and upgrade features. These systems include the following service features to make troubleshooting and repair easy and effective:

- Dell Diagnostics, which checks for hardware problems (if the system can boot)
- Embedded server management hardware, which monitors temperatures and voltages throughout the system and notifies you if the system overheats, if a system cooling fan malfunctions, or a power supply fails
- Optional redundant, hot-plug power supplies

The Dell PowerEdge 2400 system chassis simplifies removing and replacing computer components. You can perform processor and memory upgrades without removing the system board. The Dell-designed small computer system interface (SCSI) backplane board and hard-disk drive carriers eliminate the extensive cabling and drive configuration usually required for a SCSI subsystem.

The following upgrade options are offered for the Dell PowerEdge 2400 systems:

- Additional microprocessors
- Additional memory
- An integrated redundant arrays of independent disks (RAID) controller
- A 1 x 6 or 1 x 4 SCSI backplane
- A variety of expansion-card options
- Dual redundant, hot-plug power supplies
- A Dell OpenManage Remote Assistant Card 2 (DRAC 2) for advanced server management

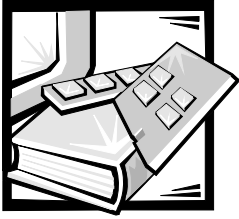

CHAPTER 2

Checking the Basics

If your Dell™ PowerEdge™ 2400 system is not working as expected, begin troubleshooting using the procedures in this section. This section guides you through some initial checks and procedures that can solve basic computer problems. It can also direct you to the appropriate section for detailed troubleshooting information and procedures to solve more complex problems.



NOTE: When you see the question "Is the problem resolved?" in a troubleshooting procedure, perform the operation that caused the problem.

Backing Up Files

If the system is behaving erratically, back up the files on the hard-disk drives immediately. See the documentation that came with the operating system for instructions on how to back up the files.

Basic Checks

The following procedure leads you through the checks necessary to solve some basic computer problems:

1. Was an alert message issued by the Dell OpenManage™ Hardware Instrumentation Package (HIP) server management application program?

Yes. Go to "Alert Log Messages From the Dell OpenManage HIP Application Program" in Chapter 3, "Messages and Codes."

No. Go to step 2.

2. Is the computer wet or damaged?

Yes. Go to Chapter 7, "Checking Inside the Computer."

No. Go to step 3.

3. Perform the steps in the next section, "Checking Connections and Switches."

Is the problem resolved?

Yes. The power to the computer system was faulty, or the connections to the computer system were loose. You have fixed the problem.

No. Go to step 4.

4. Follow the procedures described in "Look and Listen," found later in this chapter.

Did the system complete the boot routine?

Yes. Go to step 5.

No. A serious malfunction may have occurred. Go to Chapter 11, "Getting Help."

5. Did you receive a system message or beep code?

Yes. Go to "System Messages" in Chapter 3, "Messages and Codes."

No. Go to step 6.

6. Verify the settings in the System Setup program. (See Chapter 4, "Using the System Setup Program," in your *User's Guide*.)

Is the problem resolved?

Yes. The system configuration information was incorrect. You have fixed the problem.

No. Go to step 7.

7. Run the Dell Diagnostics. (See Chapter 5, "Running the Dell Diagnostics.")

Checking Connections and Switches

Improperly set switches and controls and loose or improperly connected cables are the most likely source of problems for the computer, monitor, or other peripherals (such as a printer, keyboard, mouse, or other external equipment). A quick check of all the switches, controls, and cable connections can easily solve these problems.

Figure 2-1 shows the back-panel connections on the computer. Figure 2-2 shows the front-panel controls and indicators on the computer.

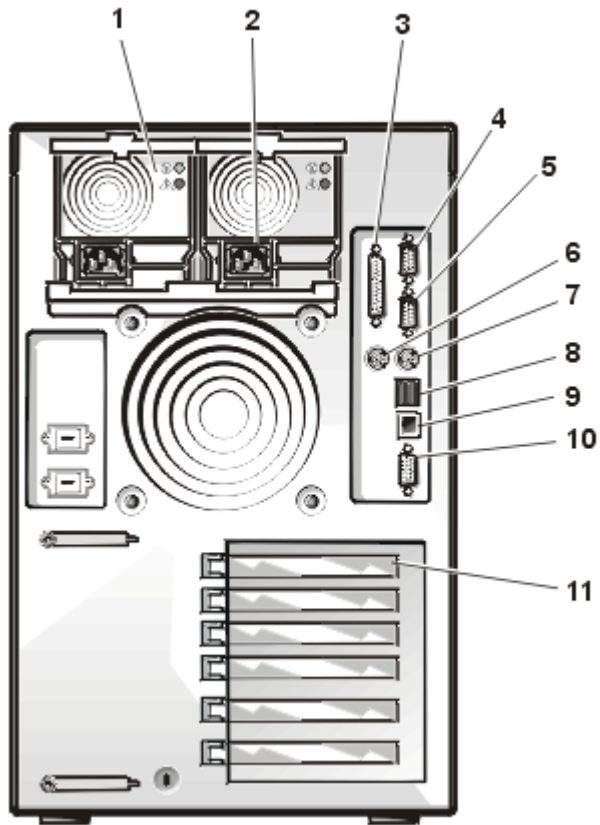

Figure 2-1. Back-Panel Features

-
- 1 Optional redundant power supplies (2)
 - 2 AC power receptacle(s)
 - 3 Parallel port connector
 - 4 Serial port 1
 - 5 Serial port 2
 - 6 Mouse connector
 - 7 Keyboard connector
 - 8 Universal Serial Bus (USB) connectors (2)
 - 9 Network interface controller (NIC) connector
 - 10 Video connector
 - 11 Expansion slots (6)
-

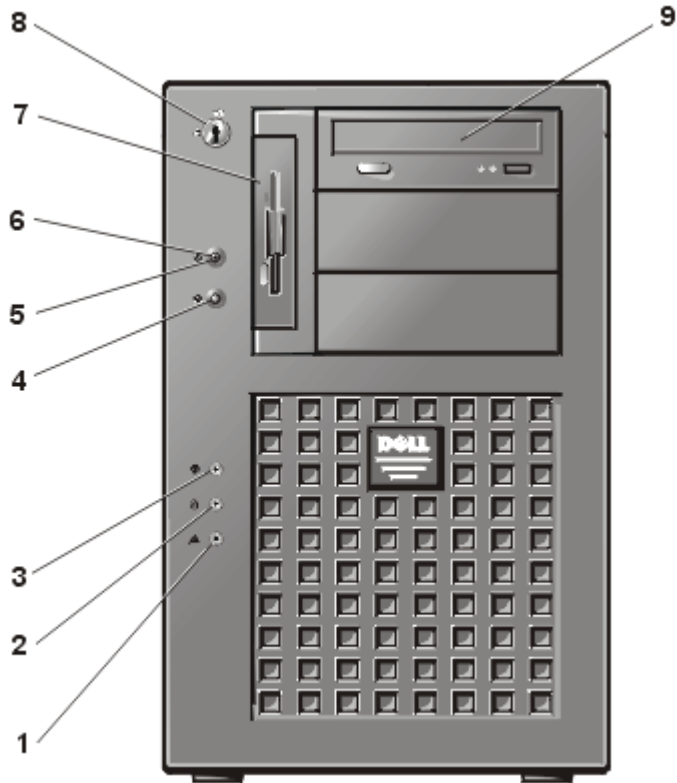

Figure 2-2. Front-Panel Features

-
- 1 System alert indicator
 - 2 Drive fault indicator
 - 3 Drive access indicator
 - 4 Reset button
 - 5 Power button
 - 6 Power indicator
 - 7 Diskette drive
 - 8 Keylock
 - 9 CD-ROM drive
-

To check all the connections and switches, perform the following steps:

1. Turn off the system, including any attached peripherals (such as the monitor, keyboard, printer, external drives, scanners, and plotters). Disconnect all the AC power cables from their electrical outlets.

2. If the computer is connected to a power strip (or power distribution unit), turn the power strip off and then on again.

Is the power strip receiving power?

Yes. Go to step 5.

No. Go to step 3.

3. Plug the power strip into another electrical outlet.

Is the power strip receiving power?

Yes. The original electrical outlet probably does not function. Use a different electrical outlet.

No. Go to step 4.

4. Plug a different system into the electrical outlet.

Does the system receive power?

Yes. The power strip is probably not functioning properly. Use another power strip.

No. Go to step 5.

5. Reconnect the system to the electrical outlet or power strip.

Make sure that all connections fit tightly together.

6. Turn on the system.

Is the problem resolved?

Yes. The connections were loose. You have fixed the problem.

No. Go to step 7.

7. Is the monitor operating properly?

Yes. Go to step 8.

No. Go to "Troubleshooting the Monitor" in Chapter 6, "Checking the Equipment."

8. Is the keyboard operating properly?

Yes. Go to step 9.

No. Go to "Troubleshooting the Keyboard" in Chapter 6, "Checking the Equipment."

9. Are the mouse and printer operating properly?

Yes. Continue with "Look and Listen" found next in this section.

No. Go to "Troubleshooting the Basic I/O Functions" in Chapter 6, "Checking the Equipment."

Look and Listen

Looking at and listening to the system is important in determining the source of a problem. Look and listen for the indications described in Table 2-1.

Table 2-1. Boot Routine Indications

Look/Listen for:	Action
An error message	See Chapter 3, "Messages and Codes."
Alert messages from the Dell OpenManage HIP software	The server management software has detected a problem inside the computer. See "Alert Log Messages From the Dell OpenManage HIP Application Program" in Chapter 3, "Messages and Codes."
The monitor's power indicator	Most monitors have a power indicator (usually on the front bezel). If the monitor's power indicator does not come on, see "Troubleshooting the Monitor" in Chapter 6, "Checking the Equipment."
The keyboard indicators	Most keyboards have one or more indicators (usually in the upper-right corner). Press the <Num Lock> key, the <Caps Lock> key, or the <Scroll Lock> key to toggle their respective keyboard indicators on and off. If the indicators do not light up, see "Troubleshooting the Keyboard" in Chapter 6, "Checking the Equipment."
The diskette-drive access indicator	The diskette-drive access indicator should quickly flash on and off when you access data on the diskette drive. If the diskette-drive access indicator does not light up, see "Troubleshooting the Diskette Drive Subsystem" in Chapter 7, "Checking Inside the Computer."

NOTE: For the full name of an abbreviation or acronym used in this table, see "Abbreviations and Acronyms."

Table 2-1. Boot Routine Indications (continued)

Look/Listen for:	Action
The hard-disk drive activity indicators	The hard-disk drive activity indicators should quickly flash on and off when you access data on the hard-disk drives. On a system running the Microsoft® Windows NT® operating system, you can test the drive by opening Windows® Explorer and clicking the icon for drive C. If the hard-disk drive access indicator does not come on, see "Troubleshooting SCSI Hard-Disk Drives" in Chapter 7, "Checking Inside the Computer."
A series of beeps	See "System Beep Codes" in Chapter 3, "Messages and Codes."
An unfamiliar constant scraping or grinding sound when you access a drive	Make sure the sound is not caused by the application program you are running. The sound could be caused by a hardware malfunction. See Chapter 11, "Getting Help," for instructions on obtaining technical assistance from Dell.

NOTE: For the full name of an abbreviation or acronym used in this table, see "Abbreviations and Acronyms."

The System Setup Program

You can easily correct certain system problems by verifying the correct settings in the System Setup program. When you boot the system, the system checks the system configuration information and compares it with the current hardware configuration. If the system hardware configuration does not match the information recorded by the System Setup program, an error message may appear on the screen.

This problem can happen if you changed the system's hardware configuration and forgot to run the System Setup program. To correct this problem, enter the System Setup program, correct the corresponding System Setup setting, and reboot the system. See Chapter 4, "Using the System Setup Program," in the *User's Guide* for detailed instructions on using the System Setup program.

The Resource Configuration Utility

If you are experiencing problems with the system, you may have a conflict between the information stored by the System Setup program and the Resource Configuration Utility. Although the Resource Configuration Utility can read changes from the System Setup program, changes are not recorded into configuration memory until you run the Resource Configuration Utility and save the new information. See Chapter 5, "Using the Resource Configuration Utility," in the *User's Guide* for detailed instructions on using the Resource Configuration Utility and saving new information.

If after using the Resource Configuration Utility you have not resolved the problem, see Chapter 5, "Running the Dell Diagnostics."

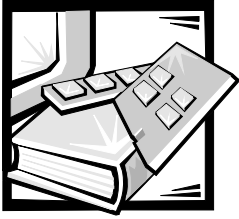

CHAPTER 3

Messages and Codes

Applications, operating systems, and the computer itself are capable of identifying problems and alerting you to them. When a problem occurs, a message may appear on the monitor screen or a beep code may sound.

Several different types of messages can indicate when the system is not functioning properly:

- System messages
- System beep codes
- Warning messages
- Diagnostics messages
- Alert messages
- Small computer system interface (SCSI) hard-disk drive indicator codes

This section describes each type of message and lists the possible causes and actions you can take to resolve any problems indicated by a message. To determine what type of message you have received, read the following sections.

System Messages

System messages alert you to a possible operating system problem or to a conflict between the software and hardware. Table 3-1 lists the system error messages that can occur and the probable cause for each message.



NOTE: If you receive a system message that is not listed in Table 3-1, check the documentation for the application that is running when the message appears and/or the operating system documentation for an explanation of the message and recommended action.

Table 3-1. System Messages

Message	Cause	Corrective Action
Address mark not found	Faulty diskette/tape drive subsystem or hard-disk drive subsystem (defective system board)	Replace the system board. See Chapter 11, "Getting Help," for instructions on obtaining technical assistance.
Alert! Maximum memory size exceeded. Limiting memory size to 2 MB	System supports up to 2 MB of memory	Remove one or more DIMMs so that all DIMMs are the same type.
Alert! Unsupported memory in DIMM slot(s) <i>n</i>	Unsupported DIMM(s) installed in specified slot(s)	Replace one or more DIMMs so that all DIMMs are the same type.
Alert! Single-bit memory error previously detected in <i>xxxx xxxxh</i>	Improperly seated or faulty DIMMs	Remove and reseal the DIMMs. If the problem persists, replace the DIMMs. See Chapter 11, "Getting Help," for instructions on obtaining technical assistance.
Alert! Uncorrectable memory error previously detected in <i>xxxx xxxxh</i>	Improperly seated or faulty DIMMs	Remove and reseal the DIMMs. If the problem persists, replace the DIMMs. See Chapter 11, "Getting Help," for instructions on obtaining technical assistance.
Attachment failed to respond	Diskette drive or hard-disk drive controller cannot send data to associated drive	Replace the drive's interface cable.
Auxiliary device failure	Mouse cable connector loose or improperly connected, defective mouse	Check the mouse cable connection. If the problem persists, replace the mouse.
Bad error-correction code(ECC) on disk read Controller has failed	Faulty diskette/tape drive subsystem or hard-disk drive subsystem (defective system board)	Replace the system board. See Chapter 11, "Getting Help," for instructions on obtaining technical assistance.
CPUs with different level 2 cache sizes detected	Two different types of microprocessors are installed	Install a correct version of the microprocessor so both microprocessors have the same level 2 cache size.
Data error	Faulty diskette, diskette drive, or hard-disk drive	Replace the diskette, diskette drive, or hard-disk drive.

NOTE: For the full name of an abbreviation or acronym used in this table, see "Abbreviations and Acronyms."

Table 3-1. System Messages (continued)

Message	Cause	Corrective Action
Decreasing available memory	One or more DIMMs improperly seated or faulty	Remove and reseat the DIMMs. If the problem persists, replace the DIMMs. See Chapter 11, "Getting Help," for instructions on obtaining technical assistance.
Diskette drive 0 seek failure	Faulty or improperly inserted diskette, incorrect configuration settings in System Setup program, loose diskette/tape drive interface cable, or loose power cable	Replace the diskette. Run the System Setup program to correct the diskette drive type. See Chapter 4, "Using the System Setup Program," in the <i>User's Guide</i> for instructions. Check the diskette/tape drive interface cable and power cable connections to the drive.
Diskette drive 1 seek failure		
Diskette read failure	Faulty diskette, faulty or improperly connected diskette/tape drive interface cable, or loose power cable	Check the diskette/tape drive interface cable and power cable connections to the drive. See Chapter 9, "Installing Drives in the External Bays." Replace the diskette-drive interface cable.
Diskette subsystem reset failed	Faulty diskette/tape drive controller (defective system board)	Replace the system board. See Chapter 11, "Getting Help," for instructions on obtaining technical assistance.
Diskette write protected	Diskette write-protect feature activated	Move the write-protect tab on the diskette.
Drive not ready	Diskette missing from or improperly inserted in diskette drive	Reinsert or replace the diskette.
Embedded server management error	Embedded server management memory may be temporarily corrupted	Shut down the system to clear the memory, and then restart the system. If the problem persists, see Chapter 11, "Getting Help," for instructions on obtaining technical assistance.
Embedded server management is not present		
Gate A20 failure	Faulty keyboard controller (defective system board)	Replace the system board. See Chapter 11, "Getting Help," for instructions on obtaining technical assistance.

NOTE: For the full name of an abbreviation or acronym used in this table, see "Abbreviations and Acronyms."

Table 3-1. System Messages (continued)

Message	Cause	Corrective Action
General failure	Operating system corrupted or not installed properly	Reinstall the operating system.
Hard disk controller failure	Incorrect configuration settings in System Setup program, improperly connected hard-disk drive, faulty hard-disk drive controller subsystem (defective system board), or loose power cable	Check the hard-disk drive configuration settings in the System Setup program. See Chapter 4, "Using the System Setup Program," in the <i>User's Guide</i> for instructions. Reinstall the hard-disk drive. Check the interface cable and power cable connections to the backplane board. See Chapter 10, "Installing Hard-Disk Drives."
Invalid configuration information - please run SETUP program	Incorrect ISA_CLR jumper configuration, incorrect configuration settings in System Setup program, or faulty battery	Remove the plug from the ISA_CLR jumper. See Appendix A, "Jumpers, Switches, and Connectors," for instructions. Check the System Setup configuration settings. See Chapter 4, "Using the System Setup Program," in the <i>User's Guide</i> for instructions. Replace the battery. See Chapter 8, "Installing System Board Options."
Invalid CPU speed detected	Microprocessor not supported by system	Install a correct version of the microprocessor in the specified microprocessor connector.
Invalid NVRAM configuration, resource reallocated	System detected and corrected a resource conflict when system resources were allocated using the Resource Configuration Utility	No action is required.
I/O parity interrupt at address	Expansion card improperly installed or faulty	Reinstall the expansion cards (see Chapter 8, "Installing System Board Options"). If the problem persists, replace the expansion card.

NOTE: For the full name of an abbreviation or acronym used in this table, see "Abbreviations and Acronyms."

Table 3-1. System Messages (continued)

Message	Cause	Corrective Action
Keyboard failure	Keyboard cable connector loose or improperly connected, defective keyboard, or defective keyboard/mouse controller (defective system board)	Check the keyboard cable connection. Replace the keyboard. If the problem persists, replace the system board. See Chapter 11, "Getting Help," for instructions on obtaining technical assistance.
Keyboard controller failure	Defective keyboard/mouse controller (defective system board)	Replace the system board. See Chapter 11, "Getting Help," for instructions on obtaining technical assistance.
Keyboard data line failure	Keyboard cable connector loose or improperly connected, defective keyboard, or defective keyboard/mouse controller (defective system board)	Check the keyboard cable connection. Replace the keyboard. If the problem persists, replace the system board. See Chapter 11, "Getting Help," for instructions on obtaining technical assistance.
Keyboard stuck key failure		
Memory address line failure at <i>address</i> , read <i>value</i> expecting <i>value</i>	Faulty or improperly seated DIMMs or defective system board	Remove and reseat the DIMMs. If the problem persists, replace the DIMMs. See Chapter 11, "Getting Help," for instructions on obtaining technical assistance.
Memory double word logic failure at <i>address</i> , read <i>value</i> expecting <i>value</i>		
Memory odd/even logic failure at <i>address</i> , read <i>value</i> expecting <i>value</i>		
Memory write/read failure at <i>address</i> , read <i>value</i> expecting <i>value</i>		
Memory allocation error	Faulty application	Restart the application.
Memory parity interrupt at <i>address</i>	Improperly seated or faulty DIMMs	Remove and reseat the DIMMs. If the problem persists, replace the DIMMs. See Chapter 11, "Getting Help," for instructions on obtaining technical assistance.
Memory tests terminated by keystroke	POST memory test terminated by pressing the spacebar	No action is required.

NOTE: For the full name of an abbreviation or acronym used in this table, see "Abbreviations and Acronyms."

Table 3-1. System Messages (continued)

Message	Cause	Corrective Action
No boot device available	Faulty diskette, diskette/tape drive subsystem, hard-disk drive, hard-disk drive subsystem, or no boot disk in drive A	Replace the diskette or hard-disk drive. If the problem persists, replace the system board. See Chapter 11, "Getting Help," for instructions on obtaining technical assistance.
No boot sector on hard-disk drive	Incorrect configuration settings in System Setup program, or no operating system on hard-disk drive	Check the hard-disk drive configuration settings in the System Setup program. See Chapter 4, "Using the System Setup Program," in the <i>User's Guide</i> for instructions.
No timer tick interrupt	Defective system board	Replace the system board. See Chapter 11, "Getting Help," for instructions on obtaining technical assistance.
Non-system disk or disk error	Faulty diskette, diskette/tape drive subsystem, or hard-disk drive subsystem	Replace the diskette or hard-disk drive. If the problem persists, replace the system board. See Chapter 11, "Getting Help," for instructions on obtaining technical assistance.
Not a boot diskette	No operating system on diskette	Use a bootable diskette.
Processor or terminator card not installed!	No microprocessor or terminator card installed in secondary microprocessor connector	Install a terminator card or microprocessor in the secondary microprocessor connector. See Chapter 8, "Installing System Board Options" for instructions.
Read fault Requested sector not found	Faulty diskette, diskette/tape drive subsystem, or hard-disk drive subsystem (defective system board)	Replace the diskette or hard-disk drive. If the problem persists, replace the system board. See Chapter 11, "Getting Help," for instructions on obtaining technical assistance.

NOTE: For the full name of an abbreviation or acronym used in this table, see "Abbreviations and Acronyms."

Table 3-1. System Messages (continued)

Message	Cause	Corrective Action
Reset failed	Improperly connected diskette/tape drive, hard-disk drive, or power cable	Check the diskette/tape drive interface cable and power cable connections to the diskette drive. See Chapter 9, "Installing Drives in the External Bays." Replace the diskette/tape drive interface cable. Reinstall the hard-disk drive. Check the interface cable and power cable connections to the backplane board. See Chapter 10, "Installing Hard-Disk Drives."
ROM bad checksum = <i>address</i>	Expansion card improperly installed or faulty	Reinstall the expansion cards (see Chapter 8, "Installing System Board Options"). If the problem persists, replace the expansion card.
Sector not found	Defective sectors on diskette or hard-disk drive	Replace the diskette or hard-disk drive.
Seek error	Defective sectors on diskette or hard-disk drive	Replace the diskette or hard-disk drive.
Seek operation failed	Faulty diskette or hard-disk drive	Replace the diskette or hard-disk drive.
Shutdown failure	Defective system board	Replace the system board. See Chapter 11, "Getting Help," for instructions on obtaining technical assistance.
Time-of-day clock stopped	Defective battery or faulty chip (defective system board)	Replace the system battery. If the problem persists, replace the system board. See Chapter 11, "Getting Help," for instructions on obtaining technical assistance.

NOTE: For the full name of an abbreviation or acronym used in this table, see "Abbreviations and Acronyms."

Table 3-1. System Messages (continued)

Message	Cause	Corrective Action
Time-of-day not set - please run SETUP program	Incorrect Time or Date settings or defective system battery	Check the Time and Date settings. See Chapter 4, "Using the System Setup Program," in the <i>User's Guide</i> for instructions. If the problem persists, replace the system battery. If the problem still persists, replace the I/O board. See Chapter 11, "Getting Help," for instructions on obtaining technical assistance.
Timer chip counter 2 failed	Defective system board	Replace the system board. See Chapter 11, "Getting Help," for instructions on obtaining technical assistance.
Unexpected interrupt in protected mode	Improperly seated DIMMs or faulty keyboard/mouse controller chip (defective system board)	Remove and reseal the DIMMs. If the problem persists, replace the DIMMs. If the problem still persists, replace the system board. See Chapter 11, "Getting Help," for instructions on obtaining technical assistance.
Unsupported CPU detected in SLOT n	Microprocessor not supported by system	Install a correct version of the microprocessor in the specified microprocessor connector.
Unsupported CPU speed detected!		
Unsupported CPU speed in CMOS	Microprocessor not supported by BIOS	Upgrade the BIOS. See Chapter 4, "Using the System Setup Program," in the <i>User's Guide</i> for instructions.
Unsupported DIMM installed in the RAID DIMM slot!	RAID DIMM not supported by system	Install a correct version of the RAID DIMM.
Unsupported RAID key detected!	RAID hardware key not supported by system	Install the RAID hardware key for your specific system.
Utility partition not available	<F10> key was pressed during POST, but no utility partition exists on the boot hard-disk drive	Create a utility partition on the boot hard-disk drive. See "Using Assistant CD" in your <i>User's Guide</i> .

NOTE: For the full name of an abbreviation or acronym used in this table, see "Abbreviations and Acronyms."

Table 3-1. System Messages (continued)

Message	Cause	Corrective Action
Warning! Detected mode switch from RAID to SCSI on the onboard RAID channel. Potential for data loss exists! Press Y to confirm the change; press any other key to cancel.	Mode of integrated RAID controller has changed from RAID to SCSI since previous system boot	Back up information on the hard-disk drives before changing the mode of operation of the integrated SCSI controller.
Write fault Write fault on selected drive	Faulty diskette or hard-disk drive	Replace the diskette or hard-disk drive.

NOTE: For the full name of an abbreviation or acronym used in this table, see "Abbreviations and Acronyms."

System Beep Codes

When an error that cannot be reported on the monitor occurs during a boot routine, the computer may emit a series of beeps that identify the problem. The beep code is a pattern of sounds; for example, one beep followed by a second beep and then a burst of three beeps (code 1-1-3) means that the computer was unable to read the data in nonvolatile random-access memory (NVRAM). This information is valuable to the Dell technical support representative if you need to call for technical assistance.



NOTE: If the system boots without a keyboard, mouse, or monitor attached, the computer will not issue beep codes related to these peripherals.

When a beep code is emitted, record it on a copy of the Diagnostics Checklist in Chapter 11, "Getting Help," and then look it up in Table 3-2. If you are unable to resolve the problem by looking up the meaning of the beep code, use the Dell Diagnostics to identify a more serious cause. If you are still unable to resolve the problem, see Chapter 11, "Getting Help," for instructions on obtaining technical assistance.

Table 3-2. System Beep Codes

Code	Cause	Corrective Action
1-1-3	CMOS write/read failure	Replace the system board. See Chapter 11, "Getting Help," for instructions on obtaining technical assistance.
1-1-4	BIOS checksum failure	This fatal error usually requires that you replace the BIOS firmware. See Chapter 11, "Getting Help," for instructions on obtaining technical assistance.
1-2-1	Programmable interval-timer failure	Replace the system board. See Chapter 11, "Getting Help," for instructions on obtaining technical assistance.
1-2-2	DMA initialization failure	
1-2-3	DMA page register write/read failure	
1-3-1	Main-memory refresh verification failure	Remove and reseat the DIMMs. If the problem persists, replace the DIMMs. If the problem still persists, replace the system board. See Chapter 11, "Getting Help," for instructions on obtaining technical assistance.
1-3-2	No memory installed	Remove and reseat the DIMMs. If the problem persists, replace the DIMMs. If the problem still persists, replace the system board. See Chapter 11, "Getting Help," for instructions on obtaining technical assistance.
1-3-3	Chip or data line failure in the first 64 KB of main memory	Remove and reseat the DIMMs. If the problem persists, replace the DIMMs. If the problem still persists, replace the system board. See Chapter 11, "Getting Help," for instructions on obtaining technical assistance.

NOTE: For the full name of an abbreviation or acronym used in this table, see "Abbreviations and Acronyms."

Table 3-2. System Beep Codes (continued)

Code	Cause	Corrective Action
1-3-4	Odd/even logic failure in the first 64 KB of main memory	Remove and reseal the DIMMs. If the problem persists, replace the DIMMs. If the problem still persists, replace the system board. See Chapter 11, "Getting Help," for instructions on obtaining technical assistance.
1-4-1	Address line failure in the first 64 KB of main memory	
1-4-2	Parity failure in the first 64 KB of main memory	
2-1-1 through 2-4-4	Bit failure in the first 64 KB of main memory	
3-1-1	Slave DMA-register failure	Replace the system board. See Chapter 11, "Getting Help," for instructions on obtaining technical assistance.
3-1-2	Master DMA-register failure	
3-1-3	Master interrupt-mask register failure	
3-1-4	Slave interrupt-mask register failure	
3-2-4	Keyboard-controller test failure	Run the keyboard test in the Dell Diagnostics to determine whether the keyboard or keyboard controller is faulty. If the keyboard controller is faulty, replace the system board. See Chapter 11, "Getting Help," for instructions on obtaining technical assistance.

NOTE: For the full name of an abbreviation or acronym used in this table, see "Abbreviations and Acronyms."

Table 3-2. System Beep Codes (continued)

Code	Cause	Corrective Action
3-3-1	CMOS failure	Run the system board test in the Dell Diagnostics to isolate the problem.
3-3-2	System configuration check failure	Replace the system board. See Chapter 11, "Getting Help," for instructions on obtaining technical assistance.
3-3-3	Keyboard controller not detected	
3-3-4	Screen initialization failure	Run the video test in the Dell Diagnostics.
3-4-2	Screen-retrace test failure	
3-4-3	Search for video ROM failure	
4-2-1	No timer tick	Replace the system board. See Chapter 11, "Getting Help," for instructions on obtaining technical assistance.
4-2-2	Shutdown failure	
4-2-3	Gate A20 failure	Replace the system board. See Chapter 11, "Getting Help," for instructions on obtaining technical assistance.
4-2-4	Unexpected interrupt in protected mode	Ensure that all expansion cards are properly seated, and then reboot the system.
4-3-1	Improperly seated or faulty DIMMs	Remove and reseat the DIMMs. If the problem persists, replace the DIMMs. See Chapter 11, "Getting Help," for instructions on obtaining technical assistance.
4-3-3	Defective system board	Replace the system board. See Chapter 11, "Getting Help," for instructions on obtaining technical assistance.

NOTE: For the full name of an abbreviation or acronym used in this table, see "Abbreviations and Acronyms."

Table 3-2. System Beep Codes (continued)

Code	Cause	Corrective Action
4-3-4	Time-of-day clock stopped	Replace the battery. If the problem persists, replace the system board. See Chapter 11, "Getting Help," for instructions on obtaining technical assistance.
4-4-1	Super I/O chip failure (defective system board)	Replace the system board. See Chapter 11, "Getting Help," for instructions on obtaining technical assistance.
4-4-2	Parallel-port test failure (defective system board)	Replace the system board. See Chapter 11, "Getting Help," for instructions on obtaining technical assistance.
4-4-3	Math coprocessor failure (defective microprocessor)	Remove and reseat the specified microprocessor. If the problem still persists, replace the microprocessor. See Chapter 11, "Getting Help," for instructions on obtaining technical assistance.
4-4-4	Cache test failure (defective microprocessor)	Remove and reseat the specified microprocessor. If the problem still persists, replace the microprocessor. See Chapter 11, "Getting Help," for instructions on obtaining technical assistance.

NOTE: For the full name of an abbreviation or acronym used in this table, see "Abbreviations and Acronyms."

Warning Messages

A warning message alerts you to a possible problem and asks you to take corrective action before the system continues a task. For example, before you format a diskette, a message may warn you that you may lose all data on the diskette, as a way to protect against inadvertently erasing or writing over the data. These warning messages usually interrupt the procedure and require you to respond by typing *y* (yes) or *n* (no).



NOTE: Warning messages are generated by either the application program or the operating system. See Chapter 4, "Finding Software Solutions," and the documentation that accompanied the operating system and application program for more information on warning messages.

Diagnostics Messages

When you run a test group or subtest in the Dell Diagnostics, an error message may result. These particular error messages are not covered in this section. Record the message on a copy of the Diagnostics Checklist (see Chapter 11, "Getting Help"), and then follow the instructions in that section for obtaining technical assistance.

Alert Log Messages From the Dell OpenManage™ HIP Application

The Dell Hardware Instrumentation Package (HIP) server management application program generates alert messages that appear in the Simple Network Management Protocol (SNMP) trap log file. To see the trap log, select any enterprise under the SNMP trap log icon. (More information about the **Alert Log** window and options is provided in the Dell HIP online help.)

Alert log messages consist of information, status, warning, and failure messages for drive, temperature, fan, and power conditions. They can assist you with identifying a problem and may provide you with information to help you resolve the problem. Table 3-3 lists some of the alert log messages from the Dell HIP application.

Table 3-3. Dell HIP Application Alert Log Messages

Message	Cause	Corrective Action
Automatic management notification has occurred	The server stopped functioning and called the notification number specified in the DC Console Actions tab.	The server will reboot if the Reset or Power Cycle option was selected in the Action on Hung Server Notification section of the System Console System tab. If neither option was selected, the system can be reset using the Remote Management feature in the Dell Remote Assistant.
Chassis intrusion detected*	The chassis of an attached system has been opened.	Check to make sure the system chassis is closed.
Fan sensor detected a failure*	A failure of one or more fans was detected by the thermal-monitoring facility in the specified server. If possible, the chassis number and fan number are provided.	Check for a possible blockage on or inadequate ventilation around the fan. If the fan is not blocked and ventilation is adequate, check fan connections. If the problem is still not resolved, see Chapter 11, "Getting Help," for instructions on obtaining technical assistance.

* Supported for local server action

NOTE: For the full name of an abbreviation or acronym used in this table, see "Abbreviations and Acronyms."

Table 3-3. Dell HIP Application Alert Log Messages (continued)

Message	Cause	Corrective Action
Fan sensor warning detected*	A fan sensor reading on the specified server has exceeded the user-settable warning thresholds. If possible, the chassis number and fan number are provided.	Check for a possible blockage of or inadequate ventilation around the fan. If the fan is not blocked and ventilation is adequate, check fan connections. If the problem is still not resolved, see Chapter 11, "Getting Help," for instructions on obtaining technical assistance.
Memory ECC fault detected	An ECC error has occurred in system memory.	Run the appropriate memory test(s) from the Dell Diagnostics. See Chapter 5, "Running the Dell Diagnostics."
Temperature sensor detected a failure*	A temperature probe on the backplane board, system board, or drive carrier in the specified server has exceeded its temperature failure range. If possible, the chassis number and probe number are provided.	Check for a fan failure. If needed, replace the fan. Otherwise, turn off the system and see Chapter 11, "Getting Help," for instructions on obtaining technical assistance.
Temperature sensor warning detected*	A temperature probe on the backplane board, system board, or drive carrier in the specified server has exceeded its temperature warning range. If possible, the chassis number and probe number are provided.	Make sure the fan thresholds are set in a reasonable range. Check for a fan failure. Make sure the computer cover is properly installed. If the problem persists, turn off the system and see Chapter 11, "Getting Help," for instructions on obtaining technical assistance.
Voltage sensor detected a failure*	A failure has occurred with the system power supply or voltage probe(s) on the system board. If possible, the chassis number and probe number are provided.	Check the power supply and backplane board connections. If the power supply is connected properly, see Chapter 11, "Getting Help," for instructions on obtaining technical assistance.
Voltage sensor warning detected*	The voltage probe on the backplane board, system board, or power supply for the specified server has exceeded its warning range. If possible, the chassis number and probe number are provided.	Make sure the user-settable voltage thresholds are set correctly. If the problem persists, check the power supply and backplane board connections. If the power supply is connected properly, see Chapter 11, "Getting Help," for instructions on obtaining technical assistance.

* Supported for local server action

NOTE: For the full name of an abbreviation or acronym used in this table, see "Abbreviations and Acronyms."

SCSI Hard-Disk Drive Indicator Codes

If a redundant arrays of independent disks (RAID) controller such as the optional PowerEdge Expandable RAID Controller (PERC) 2/Si controller is installed in the system, three light-emitting diode (LED) indicators on each of the hard-disk drive carriers provide information on the status of the SCSI hard-disk drives (see Figure 3-1). The SCSI backplane firmware controls the drive online and drive failure indicators.

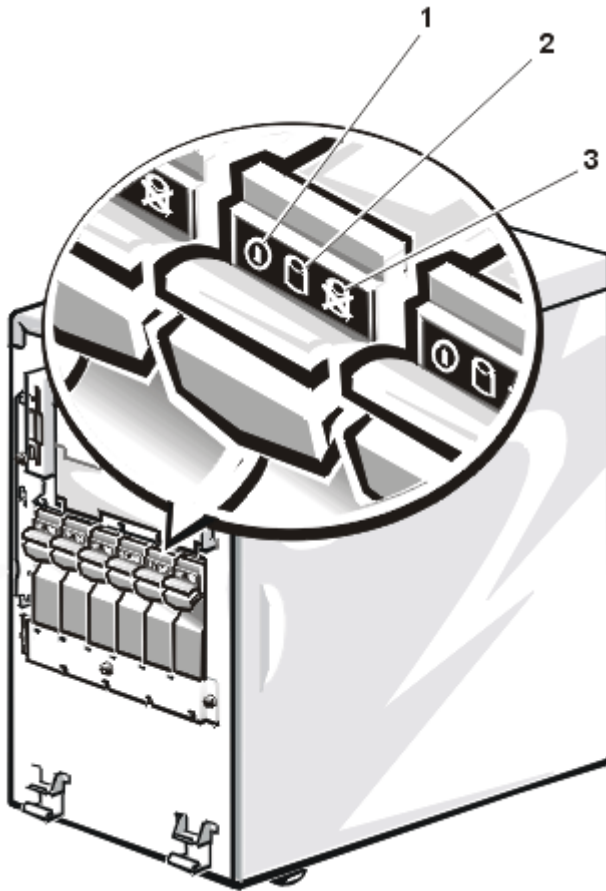

Figure 3-1. Hard-Disk Drive Indicators

-
- 1 Drive online indicator
 - 2 Drive activity indicator
 - 3 Drive failure indicator
-

Table 3-4 lists the drive indicator patterns established by the SCSI backplane firmware. Different patterns are displayed as drive events occur in the system. For example, in the event of a hard-disk drive failure, the "drive failed" pattern appears. After the drive is selected for removal, the "drive being prepared for removal" pattern appears, followed by the "drive ready for insertion or removal" pattern. After the replacement drive is installed, the "drive being prepared for operation" pattern appears, followed by the "drive online" pattern.



NOTE: If you do not have a RAID controller installed, you will see only the "drive online" and "drive bay empty" indicator patterns.

Table 3-4. SCSI Hard-Disk Drive Indicator Patterns

Condition	Indicator Code
Identify drive	All three drive status indicators blink simultaneously.
Drive being prepared for removal	The three drive status indicators flash sequentially.
Drive ready for insertion or removal	All three drive status indicators are off.
Drive being prepared for operation	The drive online indicator is on. The drive activity light may flash briefly.
Drive bay empty	All three drive status indicators are off.
Drive predicted failure	The drive online indicator is on. The drive failure indicator blinks on briefly each second.
Drive failed	The drive online indicator turns off. The drive failure indicator blinks off briefly each second.
Drive rebuilding	The drive online indicator blinks rapidly.
Drive online	The drive online indicator is on.

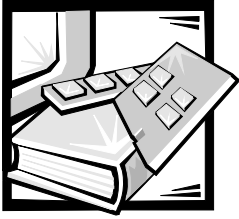

CHAPTER 4

Finding Software Solutions

Because most computer systems have several application programs installed in addition to the operating system, isolating a software problem can be confusing. Software errors can also appear to be hardware malfunctions at first.

Software problems can result from the following circumstances:

- Improper installation or configuration of a program
- Input errors
- Device drivers that may conflict with certain application programs
- Interrupt conflicts between devices

You can confirm that a computer system problem is caused by software by running the system board tests in the Dell Diagnostics (see Chapter 5, “Running the Dell Diagnostics”). If all tests in the test group are completed successfully, the problem is most likely caused by software.

This section provides some general guidelines for analyzing software problems. For detailed troubleshooting information on a particular program, see the documentation that accompanied the software or consult the support service for the software.

Installing and Configuring Software

Use virus-scanning software to check newly acquired application programs and files for viruses before you install the programs on the computer's hard-disk drive. Viruses can quickly use all available system memory, damage and/or destroy data stored on the hard-disk drive, and permanently affect the performance of the programs they infect. Several commercial virus-scanning programs are available for purchase.

Before you install a program, read its documentation to learn how the program works, what hardware it requires, and what its defaults are. A program usually includes installation instructions in its accompanying documentation and a software installation routine.

The software installation routine assists you in transferring the appropriate program files to the computer's hard-disk drive. Installation instructions may provide details about how to configure the operating system to successfully run the program. Always read the installation instructions before running a program's installation routine.

When you run the installation routine, be prepared to respond to prompts for information about how the computer's operating system is configured, what type of computer you have, and what peripheral devices are connected to the computer.

Using Software

The following subsections discuss errors that can occur as a result of software operation or configuration.

Error Messages

Error messages can be produced by an application program, the operating system, or the computer. Chapter 3, "Messages and Codes," provides information about the error messages that are generated by the computer. If you receive an error message that is not listed in Chapter 3, "Messages and Codes," check the operating system or application program documentation.

Input Errors

If you press a specific key or set of keys at the wrong time, a program may give you unexpected results. See the documentation that came with the application program to make sure that the values or characters you are entering are valid.

Make sure that the operating environment is set up to accommodate the programs you use. Keep in mind that whenever you change the parameters of the computer's operating environment, you may affect the successful operation of the programs. Sometimes, after modifying the operating environment, you may need to reinstall a program that no longer runs properly.

Program Conflicts

Some programs may leave portions of their setup information behind, even though you have exited from them. As a result, other programs cannot run. Rebooting the system can confirm whether these programs are the cause of the problem.

Device drivers, which are programs that use specialized subroutines, can cause problems with the computer system. For example, a variation in the way the data is sent to the monitor may require a special screen driver program that expects a certain kind of video mode or monitor. In such cases, you may have to develop an alternate method of running that particular program—by creating a start-up file made especially for that program, for example. Call the support service for the software you are using to help you with this problem.

Avoiding Interrupt Assignment Conflicts

Problems can arise if two devices attempt to use the same interrupt request (IRQ) line. To avoid this type of conflict, check the documentation for the IRQ line's default for each installed expansion card. Then consult Table 4-1 to configure the card for one of the available IRQ lines.

Table 4-1. IRQ Line Assignment Defaults

IRQ Line	Used By/Available
IRQ0	Used by the system timer
IRQ1	Used by the keyboard to signal that the output buffer is full
IRQ2	Used by interrupt controller 2
IRQ3	Used by serial port 2 (COM2 and COM4) or PCI device
IRQ4	Used by serial port 1 (COM1 and COM3) or PCI device
IRQ5	Available unless used by a secondary parallel port
IRQ6	Used by the diskette drive controller
IRQ7	Used by the primary parallel port or PCI device
IRQ8	Used by the RTC
IRQ9	Used by ACPI
IRQ10	Available
IRQ11	Available
IRQ12	Used by the PS/2 mouse port
IRQ13	Reserved for floating-point errors
IRQ14	Available
IRQ15	Used by ESM

NOTE: For the full name of an abbreviation or acronym used in this table, see "Abbreviations and Acronyms."



CHAPTER 5

Running the Dell™ Diagnostics

Unlike many diagnostic programs, the Dell Diagnostics helps you check the computer's hardware without any additional equipment and without destroying any data. By using the diagnostics, you can have confidence in the computer system's operation. If you find a problem that you cannot solve by yourself, the diagnostic tests can provide you with important information you will need when talking to Dell's technical assistance representative.

NOTICE: Use the Dell Diagnostics to test only Dell computer systems. If you use this program with other computers, incorrect computer responses or error messages may result.

Features of the Dell Diagnostics

The Dell Diagnostics provides a series of menus and options from which you choose particular device groups or devices. You can also control the sequence in which the tests are run. The diagnostic menus also have these helpful features:

- Options that let you run tests individually or collectively
- An option that allows you to choose the number of times a test is repeated
- The ability to display or print test results or to save them in a file
- Options to temporarily suspend testing if an error is detected or to terminate testing when an adjustable error limit is reached
- Help messages that briefly describe each test and its parameters
- Status messages that inform you whether device group or device tests are completed successfully
- Error messages that appear if any problems are detected

When to Use the Dell Diagnostics

Whenever a major component or device in the computer system does not function properly, you may have a component failure. As long as the microprocessor and the input and output components of the computer system (the monitor, keyboard, and diskette drive) are working, you can use the Dell Diagnostics. If you know what

component(s) you need to test, simply select the appropriate diagnostic device group(s) or subtest(s). If you are unsure about the scope of the problem, read the rest of the information in this section.

Starting the Dell Diagnostics

You can run the Dell Diagnostics from either the utility partition on your hard-disk drive or from a set of diskettes that you create from the *Dell OpenManage Server Assistant* CD.

To run the diagnostics from the utility partition, perform the following steps:

1. Start the utility partition by pressing <F10> during the power-on self-test (POST).
2. From the utility partition's main menu, select the **Run System Diagnostics** option from **Run System Utilities**.

See "Utility Partition" in Chapter 2, "Using the Dell OpenManage Server Assistant," in the *User's Guide* for additional information about the utility partition.

To run the Dell Diagnostics from the diskettes, perform the following steps:

1. Create a set of diagnostics diskettes using the *Dell OpenManage Server Assistant* CD.

See "Utility Partition" in Chapter 2, "Using the Dell OpenManage Server Assistant CD," in the *User's Guide* for information on creating diskettes.

2. Boot the system from the first diagnostics diskette.

If the system fails to boot, see Chapter 11, "Getting Help," for instructions on obtaining technical assistance.

When you start the diagnostics, the Dell logo screen appears, followed by a message telling you that the diagnostics is loading. Before the diagnostics loads into memory, a program tests the random-access memory (RAM) that will be used by the diagnostics.

If no errors are found in the RAM, the diagnostics loads, and the **Diagnostics** menu appears. The menu allows you to run all or specific diagnostic tests or to exit the Dell Diagnostics.



NOTE: Before you read the rest of this section, you may want to start the Dell Diagnostics so that you can see it on your monitor screen.

For a quick check of the system, select **Quickly Test All Devices**. This option runs only the device tests that do not require user interaction and that do not take a long time to run. Dell recommends that you choose this option first to increase the chance of tracing the source of the problem quickly. For a complete check of the system, select **Fully Test All Devices**. To check a particular area of the system, choose **Select Devices to Test**.

Selecting **Exit to MS-DOS** exits the diagnostics and returns you to your operating system environment.

To select an option from the **Diagnostics** menu, highlight the option and press <Enter>, or press the key that corresponds to the highlighted letter in the option you choose.

How to Use the Dell Diagnostics

When you select **Select Devices to Test** from the **Diagnostics** menu, the main screen of the diagnostics appears.

Information on the main screen of the diagnostics is presented in the following areas:

- Two lines at the top of the main screen identify the diagnostics and give its version number.
- On the left side of the screen, the **Device Groups** area lists the diagnostic device groups in the order they will run if you select **All** under the **Run Tests** submenu. Press the up- or down-arrow key to highlight a device group.
- On the right side of the screen, the **Devices for Highlighted Group** area lists the specific devices within a particular test group.
- Two lines at the bottom of the screen make up the menu area. The first line lists the menu options you can select; press the left- or right-arrow key to highlight an option. The second line gives information about the highlighted option.

How to Use the Device Groups Menu

The **Device Groups** menu at the bottom of the screen provides options that enable you to select and run specific diagnostic tests from the diagnostics main screen. Press the left- and right-arrow keys to select the options on the menu. As you move from one menu option to another, a brief explanation of the highlighted option appears on the bottom line of the screen.

If you want more information about a device group or device, highlight the **About** option and press <Enter>. After you read the information, press <Esc> to return to the previous screen.

Device Groups Menu Options

Five options are listed at the bottom of the diagnostics main screen: **Run Tests**, **Devices**, **Select**, **Config**, and **Help**.

There are two ways to select a menu option:

- Look on the screen to see which letter in the option is capitalized, and type that letter (for example, type **r** to select the **Run** option).

- Move the highlight to the option you want to select by pressing the left- or right-arrow key, and then press <Enter>.

Whenever one of the options is selected, additional choices become available.

The following subsections explain the menu options as listed from left to right in the **Device Groups** menu.

Run Tests

Run Tests displays seven options: **One**, **All**, **Select**, **Options**, **Results**, **Errors**, and **Help**. If you select **One**, all the devices within the highlighted device group are run. If you select **All**, all of the tests in all of the device group tests are run. (The device group tests are run in the same order as they are listed.) If you choose **Select**, only the selected device groups or the devices that you selected within the device groups are run. Before you test any device groups or devices, consider setting global parameters within **Options**. Global parameters offer you greater control over how the device group tests or device tests are run and how results are reported. **Help** displays a series of help options, including **Menu**, **Keys**, **Device**, **Group**, and **Test**.

Devices

Most of the device groups consist of several devices. Use the **Devices** option to select individual devices within the device group(s).

When you select **Devices**, the following options are displayed: **Run Tests**, **Tests**, **Select**, **Parameters**, and **Help**. Table 5-1 lists all of the possible values for each option.

Table 5-1. Devices Options

Option	Functions
Run Tests	Displays five options: Run Tests , Tests , Select , Parameters , and Help .
Tests	Allows you to select individual devices to tailor the testing process to your particular needs. You can choose one or more devices from the list. When you choose Tests , four options are displayed: Run Tests , Select , Parameters , and Help .
Select	Allows you to choose one or more devices from a particular device group. Three options are displayed: One , All , and Help .
Parameters	Determines how a particular test will be run. Table 5-2 lists all of the possible values for each option. To change Parameters options, press the spacebar, the left- and right-arrow keys, or the plus (+) and minus (-) keys.
Help	Displays a list of help topics.

Table 5-2. Parameters Options

Option	Possible Values
Number of Times to Repeat Test(s)	0001 through 9999 or 0000 , which loops indefinitely until you press <Ctrl><Break>. The default is 1 .
Maximum Errors Allowed	0000 through 9999 , where 0000 means that there is no error limit. The default is 1 .
Pause for User Response	Yes, No Allows you to decide whether tests will wait for user input. The default is Yes to wait for user input.
Message Logging	None, Errors, All Determines if any test results are saved to a file. The default is None .
Message Logging File Name	Specifies the name of the logging file if the Message Logging option is selected. The default is A: RESULT .

Select

The **Select** option in the **Device Groups** menu allows you to choose one or more devices from a particular device group. Three options are displayed: **One, All, and Help**.

Config

Choosing **Config** from the **Device Groups** menu display information about the particular device that is highlighted.

Error Messages

When you run a test in the diagnostics, error messages may result. Record the messages on a copy of the Diagnostics Checklist; also see Chapter 11, "Getting Help," for instructions on obtaining technical assistance and informing the technical assistance representative of these messages.



CHAPTER 6

Checking the Equipment

This section provides troubleshooting procedures for equipment that connects directly to the input/output (I/O) panel of the computer, such as the monitor, keyboard, mouse, or printer. Before you perform any of the procedures in this section, see "Checking Connections and Switches" in Chapter 2, "Checking the Basics." Then follow the troubleshooting procedures for the equipment that is malfunctioning.

You need the following items to perform the procedures in this section:

- The *Dell OpenManage Server Assistant CD*
- A blank, formatted diskette
- The system documentation



NOTE: When you see the question "Is the problem resolved?" in a troubleshooting procedure, perform the operation that caused the problem.

Troubleshooting the Monitor

Troubleshooting video problems involves determining which of the following items is the source of the problem:

- Monitor and monitor interface cable
- Video memory
- Video logic of the computer or a video expansion card

If information on the monitor screen is displayed incorrectly or not at all, perform the following steps to solve the problem:

1. Turn on the system, including any attached peripherals.
2. Adjust the switches and controls including the horizontal and vertical position and size, as specified in the monitor's documentation, to correct the video image.

Is the problem resolved?

Yes. You have fixed the problem.

No. Go to step 3.

3. Run the video tests in the Dell™ Diagnostics.

Is the monitor displaying text properly?

Yes. Go to step 4.

No. If a video expansion card is installed in the computer, see "Troubleshooting Expansion Cards" in Chapter 7, "Checking Inside the Computer." If no video expansion card is installed, the integrated video controller is faulty; see Chapter 11, "Getting Help," for instructions on obtaining technical assistance.

4. Run the video tests in the Dell Diagnostics.

Did the tests run successfully?

Yes. You have fixed the problem, or the problem is software-related. For information about installing video drivers, see Chapter 2, "Using the *Dell OpenManage Server Assistant* CD," in the *User's Guide*.

No. Go to step 5.

5. Turn off the system and disconnect it from the electrical outlet.

Swap the monitor with one of the same type that is working, and reconnect the system to the electrical outlet.

6. Run the video tests in the Dell Diagnostics again.

Did the tests run successfully?

Yes. The monitor must be replaced. See Chapter 11, "Getting Help," for instructions on obtaining technical assistance.

No. If a video expansion card is installed in the computer, see "Troubleshooting Expansion Cards" in Chapter 7, "Checking Inside the Computer." If no video expansion card is installed, the integrated video controller is faulty; see Chapter 11, "Getting Help," for instructions on obtaining technical assistance.

Troubleshooting the Keyboard

This procedure determines what kind of keyboard problem you may have. If a system error message indicates a keyboard problem when you start the computer system or while the Dell Diagnostics is running, perform the following steps:

1. Look at the keyboard and the keyboard cable for any signs of damage.

Press and release each key on the keyboard.

Do the keyboard and its cable appear to be free of physical damage, and do the keys work?

Yes. Go to step 3.

No. Go to step 2.

2. Swap the faulty keyboard with a working keyboard. To swap a faulty keyboard, unplug the keyboard cable from the computer's back panel and plug in a working keyboard.

Is the problem resolved?

Yes. The keyboard must be replaced. See Chapter 11, "Getting Help," for instructions on obtaining technical assistance.

No. Go to step 3.

3. Run the keyboard test in the Dell Diagnostics.

Can you use the keyboard to select the keyboard test?

Yes. Go to step 5.

No. Go to step 4.

4. Swap the faulty keyboard with a working keyboard.

5. Did the keyboard test run successfully?

Yes. The keyboard must be replaced. See Chapter 11, "Getting Help," for instructions on obtaining technical assistance.

No. The keyboard controller on the system board is faulty. See Chapter 11, "Getting Help," for instructions on obtaining technical assistance.

Troubleshooting the Basic I/O Functions

This procedure determines whether the computer's basic I/O functions are operational. If a system error message indicates an I/O port problem or the device connected to the port does not function properly, perform the following steps:

1. Enter the System Setup program, and check the **Serial Port 1**, **Serial Port 2**, and **Parallel Port** settings.

Are the communications ports set to **Enabled**?

Yes. Go to step 3.

No. Go to step 2.

2. Change the **Serial Port 1**, **Serial Port 2**, and **Parallel Port** settings to **Enabled**; then reboot the system.

Is the problem resolved?

Yes. You have fixed the problem.

No. Go to step 3.

3. Check the contents of the start-up files. See "Installing and Configuring Software" in Chapter 4, "Finding Software Solutions."

Are the port configuration commands correct?

Yes. Go to step 5.

No. Go to step 4.

4. Change the necessary statements in the start-up files. If the port problem is confined to a particular application program, see the application program's documentation for specific port configuration requirements.

Is the problem resolved?

Yes. You have fixed the problem.

No. Go to step 5.

5. Reboot the system from the diagnostics diskette, and run the serial ports test and/or the parallel ports test in the Dell Diagnostics.

Did the tests run successfully?

Yes. Go to step 6.

No. See Chapter 11, "Getting Help," for instructions on obtaining technical assistance.

6. If the problem persists, go to one of the following sections, "Troubleshooting a Parallel Printer" or "Troubleshooting a Serial I/O Device," depending on which device appears to be malfunctioning.

Troubleshooting a Parallel Printer

If the procedure in the preceding section, "Troubleshooting the Basic I/O Functions," indicates that the problem is with a parallel printer, perform the following steps:

1. Turn off the parallel printer and computer.
2. Swap the parallel printer interface cable with a known working cable.
3. Turn on the parallel printer and computer.
4. Attempt a print operation on the parallel printer.

Did the print operation run successfully?

Yes. The interface cable must be replaced. See Chapter 11, "Getting Help," for instructions on obtaining technical assistance.

No. Go to step 5.

5. Run the parallel printer's self-test.

Did the self-test run successfully?

Yes. Go to step 6.

No. The printer is probably defective. If the printer was purchased from Dell, see Chapter 11, "Getting Help," for instructions on obtaining technical assistance.

6. Attempt another print operation on the parallel printer.

Did the print operation run successfully?

Yes. You have fixed the problem.

No. See Chapter 11, "Getting Help," for instructions on obtaining technical assistance.

Troubleshooting a Serial I/O Device

If the procedure in "Troubleshooting the Basic I/O Functions" found earlier in this chapter indicates that the problem is with a device connected to one of the serial ports, perform the following steps:

1. Turn off the computer and any peripheral devices connected to the serial ports.

Are two serial devices connected to the computer?

Yes. Go to step 2.

No. Go to step 4.

2. Disconnect the devices from serial ports 1 and 2, and connect the malfunctioning serial device to the opposite port.

3. Turn on the computer and the reconnected serial device.

Is the problem resolved?

Yes. The serial port may be defective. See Chapter 11, "Getting Help," for instructions on obtaining technical assistance.

No. Go to step 4.

4. Swap the interface cable that connects the device to the serial port with a known working cable.

Is the problem resolved?

Yes. The interface cable must be replaced. See Chapter 11, "Getting Help," for instructions on obtaining technical assistance.

No. Go to step 5.

5. Turn off the computer and the serial device, and swap the device with a comparable working device.

For example, if the serial mouse has a problem, swap it with a serial mouse that you know is working properly.

6. Turn on the computer and the serial device.

Is the problem resolved?

Yes. The serial device must be replaced. See Chapter 11, "Getting Help," for instructions on obtaining technical assistance.

No. See Chapter 11, "Getting Help," for instructions on obtaining technical assistance.

Troubleshooting a USB Device

If a system error message indicates a problem with the USB ports or the device connected to the port does not function properly, perform the following steps:

1. Enter the System Setup program, and check that the USB ports are enabled.
2. Turn off the computer and any devices connected to the USB ports.

Are two USB devices connected to the computer?

Yes. Go to step 3.

No. Go to step 5.

3. Disconnect the devices from USB ports 1 and 2, and connect the malfunctioning device to the opposite port.
4. Turn on the computer and the reconnected device.

Is the problem resolved?

Yes. The USB port may be defective. See Chapter 11, "Getting Help," for instructions on obtaining technical assistance.

No. Go to step 5.

5. If possible, swap the interface cable that connects the device to the USB port with a known working cable.

Is the problem resolved?

Yes. The interface cable must be replaced. See Chapter 11, "Getting Help," for instructions on obtaining technical assistance.

No. Go to step 6.

6. Turn off the computer and the USB device, and swap the device with a comparable working device.

7. Turn on the computer and the USB device.

Is the problem resolved?

Yes. The USB device must be replaced. See Chapter 11, "Getting Help," for instructions on obtaining technical assistance.

No. See Chapter 11, "Getting Help," for instructions on obtaining technical assistance.



CHAPTER 7

Checking Inside the Computer

This section provides troubleshooting procedures for components inside the computer. Before you start any of the procedures in this section, take the following steps:

- Perform the procedures described in "Checking Connections and Switches" and "The System Setup Program" in Chapter 2, "Checking the Basics."
- Read the safety instructions in "Safety First—For You and Your Computer."

You need the following items to perform the procedures in this section:

- The *Dell OpenManage Server Assistant* CD and a blank, formatted 3.5-inch diskette
- The *Dell PowerEdge 2400 Systems User's Guide*
- The key to the system keylock



NOTE: When you see the question "Is the problem resolved?" in a troubleshooting procedure, perform the operation that caused the problem.

Safety First—For You and Your Computer

The procedures in this guide require that you remove the cover and work inside the computer. While working inside the computer, do not attempt to service the computer except as explained in this guide and elsewhere in Dell™ documentation. Always follow the instructions closely.



WARNING FOR YOUR PERSONAL SAFETY AND PROTECTION OF THE EQUIPMENT

Before starting to work on the computer, perform the following steps in the sequence listed:

- 1. Turn off your computer and any peripherals (unless you are installing or removing a hard-disk drive).**
- 2. Ground yourself by touching an unpainted metal surface on the chassis, such as the metal around the card-slot openings at the back of the computer, before touching anything inside your computer.**

3. **While you work, periodically touch an unpainted metal surface on the computer chassis to dissipate any static electricity that might harm internal components.**
4. **Disconnect your computer and peripherals from their power sources (unless you are installing or removing a hard-disk drive). Also, disconnect any telephone or telecommunication lines from the computer.**
5. **Doing so reduces the potential for personal injury or shock.**

In addition, Dell recommends that you periodically review the safety instructions for this system.

Removing and Replacing the Computer Covers

The computer is enclosed by a front bezel and a left- and right-side cover. To troubleshoot problems inside the computer, you may need to remove the front bezel and one or both of the side covers. Removal of the right-side computer cover allows access to the system board, small computer system interface (SCSI) backplane board, and external SCSI devices. Removal of the left-side computer cover permits access to the diskette-drive interface cable.

Removing the Computer Covers

To remove the computer covers, perform the following steps:

1. Observe the precautions in "Safety First—For You and Your Computer." Also observe the safety instructions.
2. Turn the keylock on the front bezel of the computer to the unlocked position.
3. Grasp the bezel by the indentations on each side of the external drive bays and pull it slightly away from the chassis to release the two detents on the back of the bezel.
4. Pivot the bezel downward (see Figure 7-1) until it is at right angles to the computer chassis.

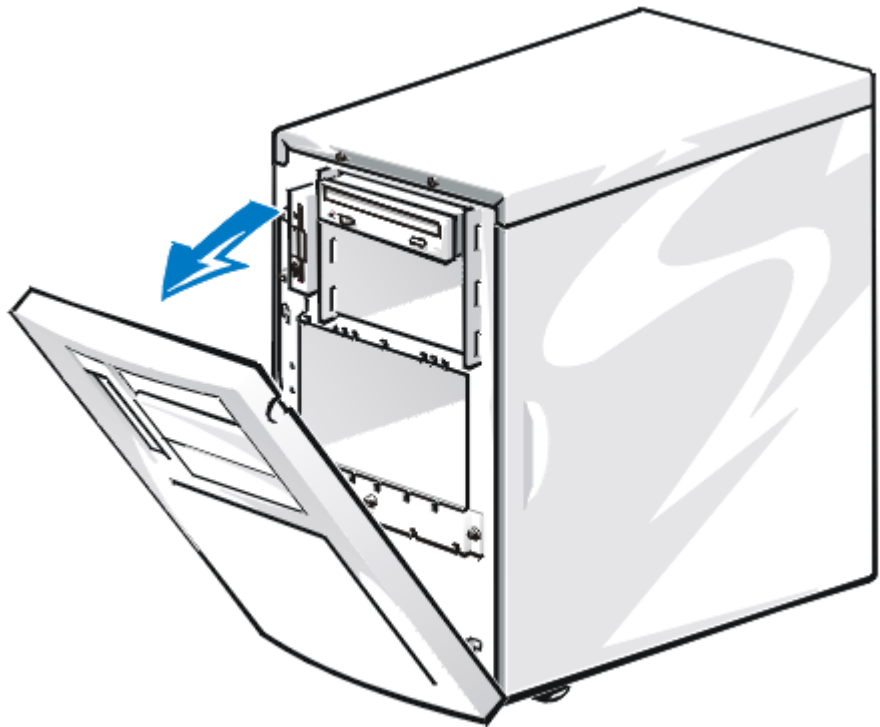

Figure 7-1. Opening the Front Bezel

5. Grasp the bezel along the edge adjacent to the computer chassis and unsnap the bezel to remove it from the chassis.
6. Loosen the three thumbscrews along the front edge of either side cover (see Figure 7-2).

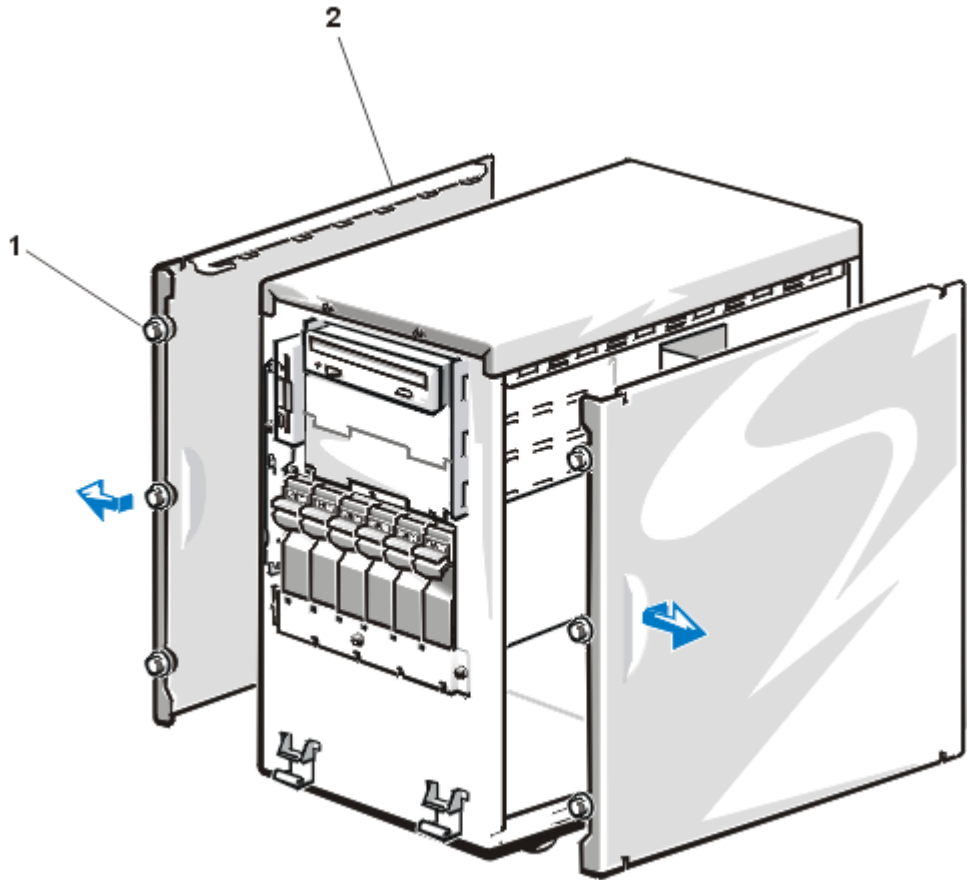

Figure 7-2. Removing the Computer Covers

-
- | | |
|---|--------------------------|
| 1 | Thumbscrew (3 per cover) |
| 2 | Cover (2) |
-

7. Slide one cover about a centimeter (a half-inch) toward the front of the computer, and grasp the top of the cover at both ends. Rotate the top edge of the cover away from the chassis, and lift it away from the chassis.
8. Repeat steps 6 and 7 to remove the remaining side cover, if necessary.

Replacing the Computer Covers

To replace a computer cover, perform the following steps.

NOTICE: Make sure that there are no cables or cable connectors lying on the top diskette drive in the upper drive cage. Foreign objects on top of the drive can interfere with drive operation and permanently damage the drive.

1. Check all cable connections, especially those that might have come loose during your work. Fold cables out of the way so that they do not catch on the computer cover.
2. Check that no tools or parts (including screws) are left inside the computer.
3. Fit the cover over the side rail at the bottom of the chassis, and slide it closed.
4. Secure the cover with the three thumbscrews.
5. Make sure the keylock is in the unlocked position.
6. Snap the two tabs near the lower inside edge of the front bezel into the corresponding metal clips on the chassis, and pivot the bezel upwards into its closed position.
7. Set the keylock to the locked position.

Removing and Replacing the Cooling Shroud

The plastic cooling shroud inside the system is used to improve airflow over the microprocessors. You may need to remove this shroud to access certain components on the system board.

Removing the Cooling Shroud

To remove the cooling shroud, perform the following steps:

1. Turn off the system, including any attached peripherals, and disconnect the power cable from the electrical outlet.

NOTICE: See "Protecting Against Electrostatic Discharge" in the safety instructions.

2. Remove the right-side computer cover.
3. Unscrew and remove the two retention pins (see Figure 7-3).

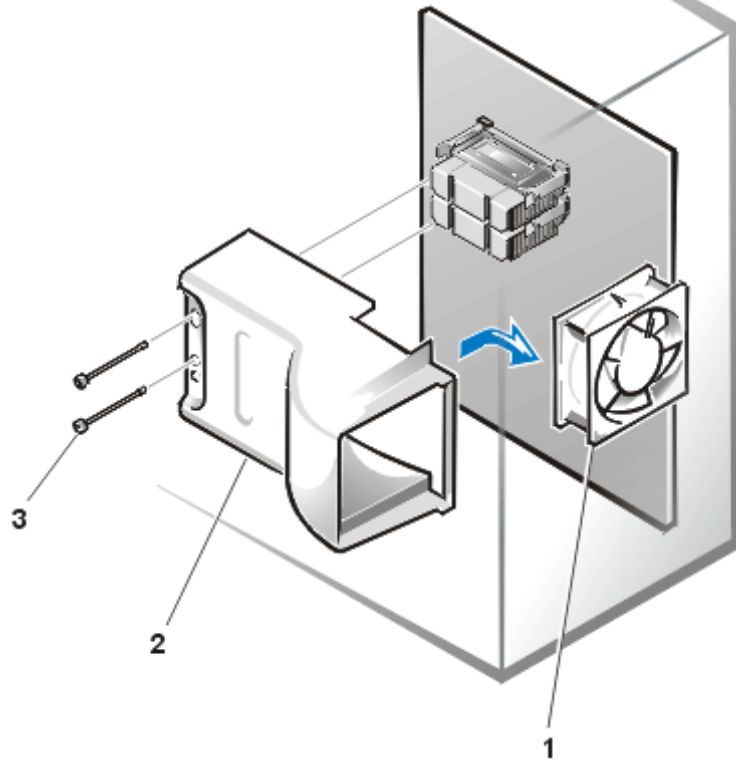

Figure 7-3. Removing the Cooling Shroud

-
- 1 Cooling fan
 - 2 Cooling shroud
 - 3 Retention pins (2)
-

4. Remove the shroud by lifting the end of the shroud closest to the micro-processor(s) until the opposite end of the shroud disengages from the cooling fan on the system back panel.

Replacing the Cooling Shroud

To replace the cooling shroud, perform the following steps:

1. Hook the upper edge of the large opening on the end of the cooling shroud over the top of the cooling fan on the system back panel.
2. Lower the other end of the shroud into place over the microprocessor(s).
3. Secure the shroud by reinstalling the two retention pins.

Inside the Chassis

In Figure 7-4, the cover on the right side of the computer is removed to provide an interior view. Figure 7-4 also identifies the drive bays. Refer to these illustrations to locate interior features and components discussed later in this guide.

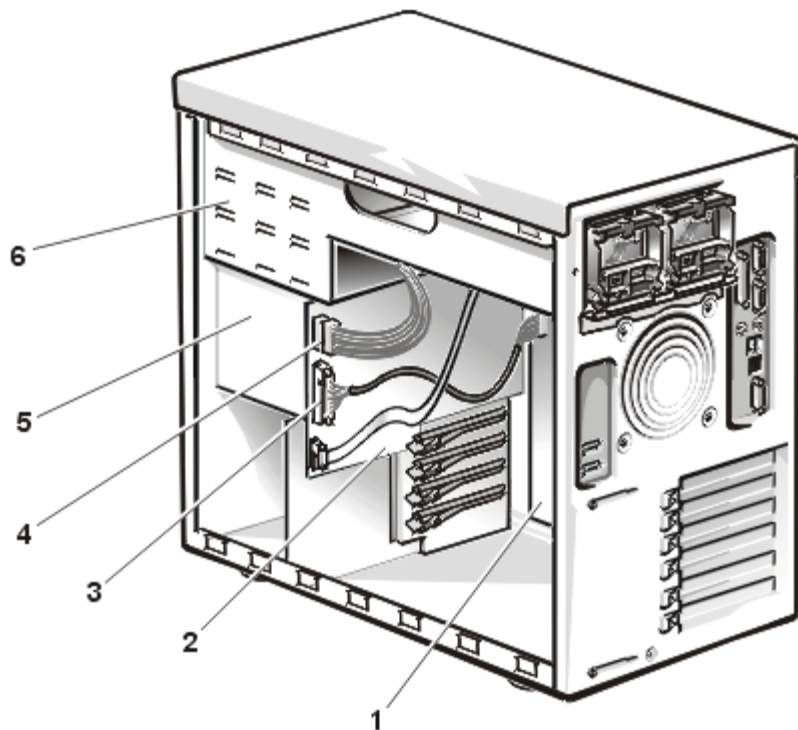

Figure 7-4. Inside the System (Right-Side View)

1	System board	4	DC power cable
2	SCSI backplane board	5	Hard-disk drive bays
3	Interface cable	6	External drive bays

The system board holds the computer's control circuitry and other electronic components. Some hardware options are installed directly on the system board. The external drive bays provide space for up to three half-height 5.25-inch drives, typically CD-ROM drives or tape drives. The diskette drive bay holds a 3.5-inch diskette drive. The hard-disk drive bays provide space for up to four 1.6-inch or six 1-inch SCSI hard-disk drives. These hard-disk drives are connected to a SCSI host adapter on the system board or on an expansion card, via the SCSI backplane board.

When you look inside the computer, note the power cables leading from the power supply(s). The power cables supply power to the system board, SCSI backplane board, externally accessible drives, and any expansion cards that connect to external peripherals.

For non-SCSI drives such as the diskette drive, an interface cable connects each drive to an interface connector on the system board or on an expansion card. For SCSI devices, interface cables connect externally accessible SCSI devices and the SCSI backplane board to a SCSI host adapter either on the system board or on an expansion card. (For more information, see Chapter 9, "Installing Drives in the External Bays," and Chapter 10, "Installing Hard-Disk Drives.")

During an installation or troubleshooting procedure, you may be required to change a jumper or switch setting. For information on the system board jumpers, see Appendix A, "Jumpers, Switches, and Connectors."

Responding to a Dell OpenManage™ Hardware Instrumentation Package Alert Message

The Dell OpenManage Hardware Instrumentation Package (HIP) server management application program monitors critical system voltages and temperatures, the system cooling fans, and the status of the SCSI hard-disk drives in the computer. The application program generates alert messages that appear in the Simple Network Management Protocol (SNMP) trap log file. More information about the **Alert Log** window and options is provided in the Dell OpenManage HIP online help and the HP OpenView *User's Guide*.

Troubleshooting a Wet Computer

Liquid spills, splashes, and excessive humidity can cause damage to the system. If an external device (such as a printer or an external drive) gets wet, contact the device manufacturer for instructions. If the computer gets wet, perform the following steps:

1. Turn off the system, including any attached peripherals, and disconnect the system from the electrical outlet.

NOTICE: See "**Protecting Against Electrostatic Discharge**" in the safety instructions.

2. Remove the computer covers.
3. Let the computer dry for at least 24 hours.
Make sure that it is thoroughly dry before proceeding.
4. Remove all expansion cards installed in the computer.
5. Replace the computer covers, reconnect the system to the electrical outlet, and turn on the system.

Does the system have power?

Yes. Go to step 6.

No. See Chapter 11, "Getting Help," for instructions on obtaining technical assistance.

6. Turn off the system, disconnect it from the electrical outlet, remove the right-side computer cover, and reinstall all expansion cards you removed in step 4.
7. Replace the computer cover, and reconnect the system to the electrical outlet.
8. Run the Dell Diagnostics and test the system.

Did the tests run successfully?

Yes. The system is operating properly.

No. See Chapter 11, "Getting Help," for instructions on obtaining technical assistance.

Troubleshooting a Damaged Computer

If the computer was dropped or damaged while being moved, you should check the computer to see if it functions properly. If an external device attached to the computer is dropped or damaged, contact the manufacturer of the device for instructions or see Chapter 11, "Getting Help," for information on obtaining technical assistance from Dell.

To troubleshoot a damaged computer, perform the following steps:

1. Turn off the system, including any attached peripherals, and disconnect the system from its electrical outlet.

NOTICE: See "Protecting Against Electrostatic Discharge" in the safety instructions.

2. Remove the computer covers.

Check all the board and card connections in the computer.

3. Check the following connections:
 - Expansion-card connections to the system board
 - Drive carrier connections to the SCSI backplane board
4. Verify all internal cable and component connections.

Make sure that all cables are properly connected and that all components are properly seated in their connectors and sockets.
5. Replace the computer covers and reconnect the system to the electrical outlet.
6. Run the system board tests in the Dell Diagnostics.

Did the tests run successfully?

Yes. The system is operating properly.

No. See Chapter 11, "Getting Help," for instructions on obtaining technical assistance.

Troubleshooting the Battery

If an error message indicates a problem with the battery, or if the System Setup program loses the system configuration information when the computer is turned off, the battery may be defective.

To troubleshoot the battery, perform the following steps:

1. Turn off the system, including any attached peripherals, and disconnect the system from its electrical outlet.

NOTICE: See "Protecting Against Electrostatic Discharge" in the safety instructions.

2. Remove the right-side computer cover.
3. Remove the cooling shroud.
4. Check the connection of the coin cell battery to the system board.

See "Replacing the Battery" in Chapter 8, "Installing System Board Options," for information on gaining access to the battery socket.

5. Is the battery firmly installed in the battery socket on the system board?

Yes. Go to step 7.

No. Go to step 6.

6. Reseat the battery in its socket.

7. Replace the cooling shroud and computer cover, and reconnect the system to the electrical outlet.

Is the problem resolved?

Yes. The battery was loose. You have fixed the problem.

No. Continue with this procedure.



CAUTION: There is a danger of a new battery exploding if it is incorrectly installed. Replace the battery only with the same or equivalent type recommended by the manufacturer. Discard used batteries according to the manufacturer's instructions.

8. Repeat steps 1 through 3.
9. Replace the battery.

Is the problem resolved?

Yes. The battery's charge was low. You have fixed the problem.

No. See Chapter 11, "Getting Help," for instructions on obtaining technical assistance.

Troubleshooting Redundant Power Supplies

Dell PowerEdge™ 2400 systems may contain two optional, redundant, hot-pluggable power supplies. The two indicators on the back of each power supply (see Figure 7-5) signal the power supply's current status. If the red (lower) failure indicator lights up, replace the power supply as described in the following subsection.

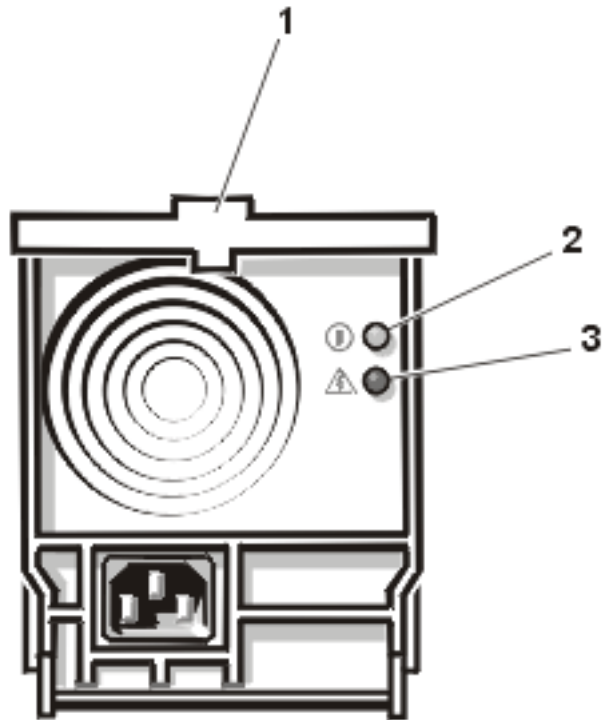

Figure 7-5. Power Supply Features

-
- | | |
|---|---------------------|
| 1 | Power supply handle |
| 2 | Power indicator |
| 3 | Failure indicator |
-

Removing and Replacing a Power Supply

To replace a power supply, perform the following steps.

NOTICE: The power supply is heavy. Support it with both hands when installing or removing it.

1. Unplug the power cord from the power supply.
2. Remove the power supply:
 - a. Using your thumb and index finger, squeeze the catch in the middle of the power supply handle (see Figure 7-5).

- b. Rotate the handle downward to release the power supply from the system chassis.
 - c. Slide the power supply out of the chassis.
3. Slide the new power supply into the chassis.

NOTICE: Do not use excessive force when sliding the power supply into the chassis.

4. Rotate the power supply handle to the closed position.

For better leverage, press against the upper corners of the handle

NOTE: The power supply will not function until the handle is closed.

5. Plug the power cord into the power supply.



Troubleshooting a Cooling Fan

Two cooling fans are installed in the Dell PowerEdge 2400 system chassis. If you observe that one of the cooling fans is not operating or if the Dell HIP server-management application issues a fan-related error message, perform the following steps to troubleshoot the problem:

1. Turn off the system, including any attached peripherals, and disconnect the AC power cable from its power source.

NOTICE: See "Protecting Against Electrostatic Discharge" in the safety instructions.

2. Remove the right-side computer cover.
3. Check the fan cable connections to the system board.
4. Replace the right-side computer cover and reconnect the system to AC power.
5. Turn on the system.

Do the fans operate properly?

Yes. You have fixed the problem.

No. See Chapter 11, "Getting Help," for instructions on obtaining technical assistance.

Troubleshooting Expansion Cards

If an error message indicates an expansion-card problem or if an expansion card seems to perform incorrectly or not at all, the problem could be a faulty connection, a conflict with software or other hardware, or a faulty expansion card. To troubleshoot expansion cards, perform the following steps:

1. Start the Resource Configuration Utility, and verify that all Industry-Standard Architecture (ISA) expansion cards have been configured correctly. Save the configuration before exiting the utility.

See Chapter 5, "Using the Resource Configuration Utility," in the *User's Guide* for instructions.

2. Turn off the system, including any attached peripherals, and disconnect the AC power cable from its power source.

NOTICE: See "Protecting Against Electrostatic Discharge" in the safety instructions.

3. Remove the right-side computer cover.
4. Verify that each expansion card is firmly seated in its connector.

Are the expansion cards properly seated in their connectors?

Yes. Go to step 6.

No. Go to step 5.

5. Reseat the expansion cards in their connectors.

Is the problem resolved?

Yes. The connection was loose. You have fixed the problem.

No. Go to step 6.

6. Verify that any appropriate cables are firmly connected to their corresponding connectors on the expansion cards.

For instructions on which cables should be attached to specific connectors on an expansion card, see the expansion card's documentation.

Are the appropriate cables firmly attached to their connectors?

Yes. Go to step 7.

No. Go to step 8.

7. Reconnect the cable connectors to the appropriate connectors on the expansion cards.

Is the problem resolved?

Yes. The cable connections were loose. You have fixed the problem.

No. Go to step 8.

8. Is an ISA expansion card installed in the system?

Yes. Go to step 9.

No. Go to step 11.

9. Inspect all jumpers and configuration switches on the ISA expansion card.

Most ISA expansion cards have configuration settings for an interrupt request (IRQ) line, a direct memory access (DMA) channel, and a base-memory or basic input/output system (BIOS) address. To keep expansion cards from conflicting with each other, you need to know both the starting memory address and the amount of memory required by each card. For instructions on jumpers and configuration settings, see the expansion card's documentation.

Is the expansion card configured correctly?

Yes. Go to step 11.

No. Go to step 10.

10. Reconfigure the card according to the instructions in the card's documentation, and reinstall the card.

Is the problem resolved?

Yes. The configuration of the ISA card was incorrect. You have fixed the problem.

No. Go to step 11.

11. Remove all expansion cards.
12. Replace the right-side computer cover, reconnect the system to AC power, and turn on the system.
13. If you have removed or replaced an ISA expansion card, run the Resource Configuration Utility and update the configuration information.

See Chapter 5, "Using the Resource Configuration Utility," in the *User's Guide* for instructions.

14. Run the system memory test in the Dell Diagnostics.

Did the test run successfully?

Yes. Go to step 15.

No. See Chapter 11, "Getting Help," for information on obtaining technical assistance.

15. Turn off the system, disconnect it from AC power, and remove the right-side computer cover.
16. Reinstall one of the expansion cards you removed in step 11, and repeat steps 12 through 13.
17. Run the system memory test in the Dell Diagnostics.

Did the test run successfully?

Yes. Go to step 18.

No. See Chapter 11, "Getting Help," for information on obtaining technical assistance.

18. Repeat steps 15 through 17 for each of the remaining expansion cards that you removed in step 11.

Have you reinstalled all of the expansion cards without encountering a test failure?

Yes. You have fixed the problem.

No. See Chapter 11, "Getting Help," for information on obtaining technical assistance.

Troubleshooting System Memory

A system memory problem can be a faulty dual in-line memory module (DIMM) or a faulty system board. If a random-access memory (RAM) error message appears, the system probably has a memory problem.

When you turn on or reboot the system, the Caps Lock and Scroll Lock indicators on the keyboard should flash momentarily and then turn off. If the **Num Lock** category in the System Setup program is set to **On**, the Num Lock indicator should flash momentarily and then remain on; otherwise, it should turn off. Abnormal operation of these indicators can result from a defective DIMM in socket DIMM_A.

To troubleshoot system memory, perform the following steps:

1. Turn on the system, including any attached peripherals.

Is there an error message indicating invalid system configuration information after the memory count is completed?

Yes. Go to step 2.

No. Go to step 8.

2. Enter the System Setup program to check the **Total Memory** or **System Memory** setting.

See Chapter 4, "Using the System Setup Program," in the *User's Guide* for instructions.

Does the amount of memory installed match the **Total Memory** or **System Memory** setting?

Yes. Go to step 9.

No. Go to step 3.

3. Turn off the system, including any attached peripherals, and disconnect the power cable from the electrical outlet.

NOTICE: See "Protecting Against Electrostatic Discharge" in the safety instructions.

4. Remove the right-side computer cover.
5. Remove the cooling shroud.
6. Reseat the DIMMs in their sockets.
7. Replace the right-side computer cover, reconnect the system to AC power, and turn on the system.
8. Enter the System Setup program and check the **Total Memory** or **System Memory** setting again.

Does the amount of memory installed match the **Total Memory** or **System Memory** setting?

Yes. Go to step 9.

No. Go to step 10.

9. Reboot the system, and observe the monitor screen and the Num Lock, Caps Lock, and Scroll Lock indicators on the keyboard.

Does the monitor screen remain blank, and do the Num Lock, Caps Lock, and Scroll Lock indicators on the keyboard remain on?

Yes. Go to step 10.

No. Go to step 14.

10. Repeat steps 3 through 5.
11. Swap the DIMM in socket DIMM_A with one of the same capacity.
12. Replace the cooling shroud and computer cover, and reconnect the system to an electrical outlet.
13. Reboot the system, and observe the monitor screen and the indicators on the keyboard.

Is the problem resolved?

Yes. You have fixed the problem.

No. Go to step 14.

14. Run the system memory test in the Dell Diagnostics.

Did the test run successfully?

Yes. You have fixed the problem.

No. See Chapter 11, "Getting Help," for instructions on obtaining technical assistance.

Troubleshooting the Video Subsystem

Troubleshooting video problems involves determining which of the following items is the source of the problem: the monitor, the monitor interface cable, the video memory, or the video logic of the computer. You can also have a high-resolution video expansion card installed, which overrides the video logic of the computer.

The following procedure troubleshoots problems with the video memory and video logic only. Before you begin, perform the procedure found in "Troubleshooting the Monitor" in Chapter 6, "Checking the Equipment," to determine whether or not the monitor is the source of the problem.

If you have a high-resolution video expansion card, first complete the steps in "Troubleshooting Expansion Cards," found earlier in this chapter, to verify that the card is configured and installed correctly.

To troubleshoot the video subsystem, perform the following steps:

1. Run the video tests in the Dell Diagnostics.

Did the tests run successfully?

Yes. The problem is not related to video hardware. Go to Chapter 4, "Finding Software Solutions."

No. Go to step 2.

2. Turn off the system, including any attached peripherals, and disconnect the power cable from the electrical outlet.

NOTICE: See "Protecting Against Electrostatic Discharge" in the safety instructions.

3. Remove the right-side computer cover.

4. Determine whether a video expansion card is installed.

Is a video expansion card installed?

Yes. Go to step 5.

No. The integrated video controller is faulty. See Chapter 11, "Getting Help," for instructions on obtaining technical assistance.

5. Remove the video expansion card, and connect the monitor interface cable to the video connector on the computer's back panel.

6. Replace the right-side computer cover, reconnect the system to AC power, and turn on the system.

Did the tests run successfully?

Yes. The video expansion card is faulty. See Chapter 11, "Getting Help," for instructions on obtaining technical assistance.

No. See Chapter 11, "Getting Help," for instructions on obtaining assistance.

Troubleshooting the System Board

A system board problem can result from a defective system board component, a faulty power supply, or a defective component connected to the system board. If an error message indicates a system board problem, perform the following steps to troubleshoot the problem:

1. Turn off the system, including any attached peripherals, and disconnect the system from its electrical outlet.

NOTICE: See "Protecting Against Electrostatic Discharge" in the safety instructions.

2. Remove the right-side computer cover.

3. Remove all expansion cards except the SCSI host adapter card and the video expansion card (if they are installed).
4. Replace the right-side computer cover, reconnect the system to AC power, and turn on the system.
5. If you removed an ISA expansion card in step 3, run the Resource Configuration Utility and update the configuration information.

See Chapter 5, "Using the Resource Configuration Utility," in the *User's Guide* for instructions.

6. Reconnect the system to the electrical outlet, and turn on the system.
7. Run the system board tests in the Dell Diagnostics.

Did the tests run successfully?

Yes. Go to step 12.

No. Go to step 13.

8. Turn off the system, disconnect it from AC power, and remove the right-side computer cover.
9. Reinstall one of the expansion cards that you removed in step 3, repeat steps 4, 5, and 6, and continue with step 10.
10. Run the system board tests again.

Did the tests run successfully?

Yes. Go to step 11.

No. Go to step 12.

11. Repeat step 8 through 10 for each of the remaining expansion cards that you removed in step 3.

Have you reinstalled all of the expansion cards without a test failure?

Yes. Go to step 12.

No. One of the expansion cards is faulty. See Chapter 11, "Getting Help," for instructions on obtaining technical assistance.

12. Disconnect the keyboard and reboot the system.

Does the system boot successfully to the operating system?

Yes. Go to step 13.

No. See Chapter 11, "Getting Help," for instructions on obtaining technical assistance.

13. Swap the keyboard with a comparable working keyboard and run the system board tests again.

Did the tests run successfully?

Yes. You have fixed the problem.

No. See Chapter 11, "Getting Help," for instructions on obtaining technical assistance.

Troubleshooting the Diskette Drive Subsystem

If the monitor displays a system error message indicating a diskette drive problem during execution of either the boot routine or the Dell Diagnostics, the problem may be caused by any of the following conditions:

- The system configuration settings do not match the physical diskette subsystem configuration.
- The diskette drive cable is not properly connected or is faulty.
- An expansion card is interfering with proper drive operations.
- A diskette drive is improperly configured.
- The diskette drive is faulty.
- The computer's power supply is not providing sufficient power for the drives.
- The computer's diskette drive logic is faulty.

To troubleshoot the diskette drive subsystem, perform the following steps:

1. Enter the System Setup program, and verify that the system is configured correctly for the **Diskette Drive A** and **Diskette Drive B** settings.

See Chapter 4, "Using the System Setup Program," in the *User's Guide* for instructions.

2. If the system configuration settings are incorrect, make the necessary corrections in the System Setup program, and then reboot the system.
3. Run the diskette drives test in the Dell Diagnostics to determine whether the diskette drive subsystem now works correctly.

Do the tests complete successfully?

Yes. If you were in the middle of another procedure, continue with the next step in the procedure you were performing.

No. Go to step 4.

4. Turn off the system, including any attached peripherals, and disconnect the AC power cable from its power source.

NOTICE: See "Protecting Against Electrostatic Discharge" in the safety instructions.

5. Remove both computer covers.
6. Check the diskette drive cabling.

Is the diskette drive securely connected to the diskette drive interface cable connector? Is the diskette drive interface cable connector securely connected to the interface connector (labeled "FLOPPY") on the system board? Is the drive's DC power cable firmly connected to the drive?

Yes. Go to step 8.

No. Go to step 7.

7. Reconnect the cable connectors.
8. Replace the computer covers, reconnect the system to AC power, and turn on the system.
9. Run the diskette drives test in the Dell Diagnostics to determine whether the diskette drive subsystem now works correctly.

Do the tests complete successfully?

Yes. You have fixed the problem.

No. Go to step 10.

10. Repeat steps 4 and 5, and remove all expansion cards.
11. Replace the computer covers, reconnect the system to AC power, and turn on the system.
12. Run the diskette drives test in the Dell Diagnostics to determine whether the diskette drive subsystem now works correctly.

Do the tests complete successfully?

Yes. An expansion card may be conflicting with the diskette drive logic, or you may have a faulty expansion card. Repeat steps 1, 2, and 3.

No. Go to step 14.

13. Repeat steps 4 and 5, and reinstall one of the expansion cards that you removed in step 10.
14. Replace the computer covers, reconnect the system to AC power, and turn on the system.

15. Run the diskette drive tests in the Dell Diagnostics to determine whether the diskette drive subsystem now works correctly.

Do the tests complete successfully?

Yes. Go to step 16.

No. Go to step 17.

16. Repeat steps 13 through 15 until all expansion cards have been reinstalled or until one of the expansion cards prevents the system from booting from the diagnostics diskette.

17. Repeat steps 4 and 5. Verify that the drive's termination is enabled and that the drive-select jumper is set to the DS1 position. For information about the drive's termination and drive-select settings, refer to the documentation for the drive.

Is the drive configured correctly?

Yes. See Chapter 11, "Getting Help," for instructions on obtaining technical assistance.

No. Go to step 19.

18. Correct the drive-select jumper and drive termination settings.
19. Replace the computer covers, reconnect the system to AC power, and turn on the system.
20. Run the diskette drives tests in the Dell Diagnostics to determine whether the diskette drive subsystem now works correctly.

Do the tests complete successfully?

Yes. You have solved the problem.

No. See Chapter 11, "Getting Help," for instructions on obtaining technical assistance.

Troubleshooting a SCSI Tape Drive

A SCSI tape drive can be an internal device installed in one of the externally accessible drive bays or an external device that attaches to a SCSI host adapter connector on the back panel of the computer. The SCSI tape drive is controlled by a SCSI host adapter card installed in the computer, which may also control other SCSI devices connected to one or more SCSI cables. SCSI devices often require device drivers for the particular operating system being used by the computer system.

Tape drive problems often result from a defective tape drive, a defective tape cartridge, or software. To troubleshoot a SCSI tape drive, perform the following steps:

1. Remove the tape that was in use when the problem occurred, and replace it with a tape that you know is not defective.

Is the problem resolved?

Yes. The original tape was defective. Replace it with a new tape. You have fixed the problem.

No. Go to step 2.

2. Reboot the system and press <F2> to enter the System Setup program.

Is **Secondary SCSI** set to **Enabled**?

Yes. Go to step 4.

No. Go to step 3.

3. Verify that any required SCSI device drivers are installed on the hard-disk drive and are configured correctly. See Chapter 3, "Installing and Configuring SCSI Drivers," in the *User's Guide* for instructions on installing and configuring the SCSI device drivers for the system's integrated SCSI host adapter or Dell PowerEdge Expandable RAID Controller host adapter card. For any other type of SCSI host adapter card, see the documentation that accompanied the SCSI host adapter card.

Are the drivers installed and configured correctly?

Yes. The SCSI device drivers were installed or configured incorrectly or were corrupted. You have fixed the problem.

No. Go to step 4.

4. Reinstall the tape backup software as instructed in the tape-backup software documentation.

Is the problem resolved?

Yes. The tape backup software was corrupted. You have fixed the problem.

No. Go to step 5.

5. Reboot the system and check for the presence of the tape drive during the ROM scan sequence.

Is the problem resolved?

Yes. The drive is correctly cabled and is receiving power. Go to step 10.

No. Go to step 6.

6. Turn off the system, including any attached peripherals, and disconnect the AC power cable from its power source.

NOTICE: See "Protecting Against Electrostatic Discharge" in the safety instructions.

7. Remove the right-side computer cover.
8. Check the SCSI cable connections to the tape drive and to the SCSI host adapter connector. If the tape drive is an internal device, check the DC power cable connection to the tape drive.

Are the cables firmly connected?

Yes. Go to step 10.

No. Go to step 9.

9. Reseat the cable connectors and replace the computer cover. Reconnect the system to AC power and turn it on.

Is the problem resolved?

Yes. You have fixed the problem.

No. Go to step 10.

10. Turn off the system, including any attached peripherals, and disconnect the AC power cable from its power source. Then remove the right-side computer cover.
11. Remove the tape drive. Then verify that the tape drive is configured for a unique SCSI ID number and that the tape drive is terminated or not terminated as appropriate. See the documentation for the tape drive for instructions on selecting the SCSI ID and enabling or disabling termination.

Is the tape drive configured correctly?

Yes. Go to step 14.

No. Go to step 12.

12. Reconfigure the tape drive's SCSI ID and termination settings as appropriate. Reinstall the tape drive, replace the computer cover, and reconnect the system to AC power and turn it on.

Is the problem resolved?

Yes. The tape drive was configured incorrectly. You have fixed the problem.

No. Go to step 13.

13. Turn off the system, including any attached peripherals, and disconnect the AC power cable from its power source. Then remove the right-side computer cover.

14. Replace the SCSI cable that connects the tape drive to the SCSI host adapter. Replace the computer cover, and then reconnect the system to AC power and turn it on.

Is the problem resolved?

Yes. You have fixed the problem.

No. See Chapter 11, "Getting Help," for instructions on obtaining technical assistance.

Troubleshooting SCSI Hard-Disk Drives

Hard-disk drive problems can be caused by a number of conditions, including problems with the drive itself, the SCSI backplane board, or a cable connected to the SCSI backplane board.

The SCSI backplane board monitors the SCSI hard-disk drives connected to the backplane board. In the event of a drive failure, systems using an optional Dell PowerEdge Expandable RAID Controller (PERC) 2/Si integrated RAID controller or optional Dell PERC 2 controller card will issue the following signals using the drive indicator lights adjacent to each SCSI hard-disk drive:

- If a drive shows signs of imminent failure, the drive online indicator stays on and the drive failure indicator blinks on briefly each second.
- If a drive has failed, the drive online indicator turns off. The drive failure indicator turns on, and blinks off briefly each second.

Other drive indicator patterns are listed in Table 3-4.

To troubleshoot a hard-disk drive problem, perform the following steps.

NOTICE: This troubleshooting procedure can destroy data stored on the hard-disk drive. Before you proceed, make sure you have backed up all the files on the hard-disk drive.

1. If the integrated SCSI host adapter is being used to control the SCSI backplane board, reboot the system and press <F2> to enter the System Setup program.

Is **Primary SCSI** set to **Enabled**?

Yes. Go to step 3.

No. Go to step 2.

2. Change the **Primary SCSI** setting to **Enabled**, and reboot the system.

Is the problem resolved?

Yes. You have fixed the problem.

No. Go to step 3.

3. Verify that the SCSI device drivers are installed and configured correctly.

See Chapter 3, "Installing and Configuring SCSI Drivers," in the *User's Guide* to determine which drivers are required and how they should be installed and configured.

Are the required SCSI device drivers installed and configured correctly?

Yes. Go to step 5.

No. Go to step 4.

4. Reinstall and/or reconfigure the required SCSI device drivers. Then reboot the system.

Is the problem resolved?

Yes. You have fixed the problem.

No. Go to step 5.

5. Remove the drive carrier and install it in another drive bay.

Is the problem resolved?

Yes. The SCSI backplane board has a defective connector. See Chapter 11, "Getting Help," for instructions on obtaining technical assistance.

No. Go to step 6.

NOTICE: See "Protecting Against Electrostatic Discharge" in the safety instructions.

6. Remove the right-side computer cover.
7. Check the SCSI cable connections to the SCSI backplane board and to the SCSI host adapter. Check the DC power cable connection to the SCSI backplane board. The SCSI cable may be connected to the SCSI host adapter on the system board or to a SCSI host adapter card in an expansion slot. See Chapter 10, "Installing Hard-Disk Drives," for the location of the cable connectors on the SCSI backplane board and the SCSI host adapter.

Are the cables firmly connected?

Yes. Go to step 9.

No. Go to step 8.

8. Reseat the cable connectors, and then reconnect the computer and peripherals to their AC power sources and turn them on.

Is the problem resolved?

Yes. The cable connections were faulty. You have fixed the problem.

No. Go to step 9.

9. Partition and logically format the hard-disk drive. If possible, restore the files to the drive. To partition and logically format the drive, see the documentation for the computer's operating system.

Is the problem resolved?

Yes. The hard-disk drive format was corrupted. You have fixed the problem.

No. See Chapter 11, "Getting Help," for instructions on obtaining technical assistance.

Troubleshooting a RAID Controller

Your system may contain an optional Dell PERC 2/Si integrated RAID controller or optional Dell PERC 2 controller card.

Troubleshooting an Integrated PERC 2/Si RAID Controller

If you encounter problems with the optional integrated RAID controller on the system board, perform the following steps to help diagnose the problem:

1. Enter the System Setup program and check the setting for the integrated RAID controller. See Chapter 4, "Using the System Setup Program," in the *User's Guide* for instructions.

Is the controller enabled?

Yes. Go to step 8.

No. Go to step 2.

2. Change the RAID controller setting to **Enabled**; then reboot the system.

Is the problem resolved?

Yes. You have fixed the problem.

No. Go to step 3.

3. Refer to the documentation provided with the RAID controller software and check the software settings.

Is the problem resolved?

Yes. You have fixed the problem.

No. Go to step 4.

4. Turn off the system, including any attached peripherals, and disconnect the power cable from the electrical outlet.

NOTICE: See "Protecting Against Electrostatic Discharge" in the safety instructions.

5. Remove the right-side computer cover.
6. Remove the cooling shroud.
7. Reseat the RAID DIMM in its socket.

See "Adding Memory" in Chapter 8, "Installing System Board Options," for general instructions on removing and replacing DIMMs.

8. Reseat the RAID hardware key in its socket.

See Figure 8-1, "System Board Features," for information on the location of the RAID hardware key.

9. Replace the cooling shroud and computer cover, reconnect the system to the electrical outlet, and reboot the system.

Is the problem resolved?

Yes. You have fixed the problem.

No. See Chapter 11, "Getting Help," for instructions on obtaining technical assistance.

Troubleshooting a PERC 2 Controller Card

If you encounter problems with a PERC 2 controller card, perform the following steps to help diagnose the problem:

1. Using the Dell Flexible Array Storage Tool (FAST) utility program, select the controller. See the *Dell Flexible Array Storage Tool (FAST) User's Guide* for details.
2. Using Microsoft® Explorer, open the **Program Files/Dell PERC2/System** folder.
3. Double-click the **getcfg.afa** file.

Two new files will be generated—**cfg.log** and **cfg.str**.

4. See Chapter 11, "Getting Help," for instructions on obtaining technical assistance. E-mail these two files for analysis when you contact Dell.

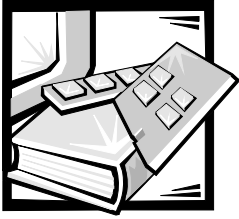

CHAPTER 8

Installing System Board Options

This section describes how to install the following options:

- Expansion cards
- Memory upgrades
- Microprocessor upgrades
- Integrated redundant arrays of independent disks (RAID) controller

This section also includes instructions for replacing the system battery, if necessary.

Use Figure 8-1 to locate the system board features.



WARNING: Before you perform the procedures in this section, you must turn off the computer and disconnect it from its AC power source. For more information, see "Safety First—For You and Your Computer" in Chapter 7.

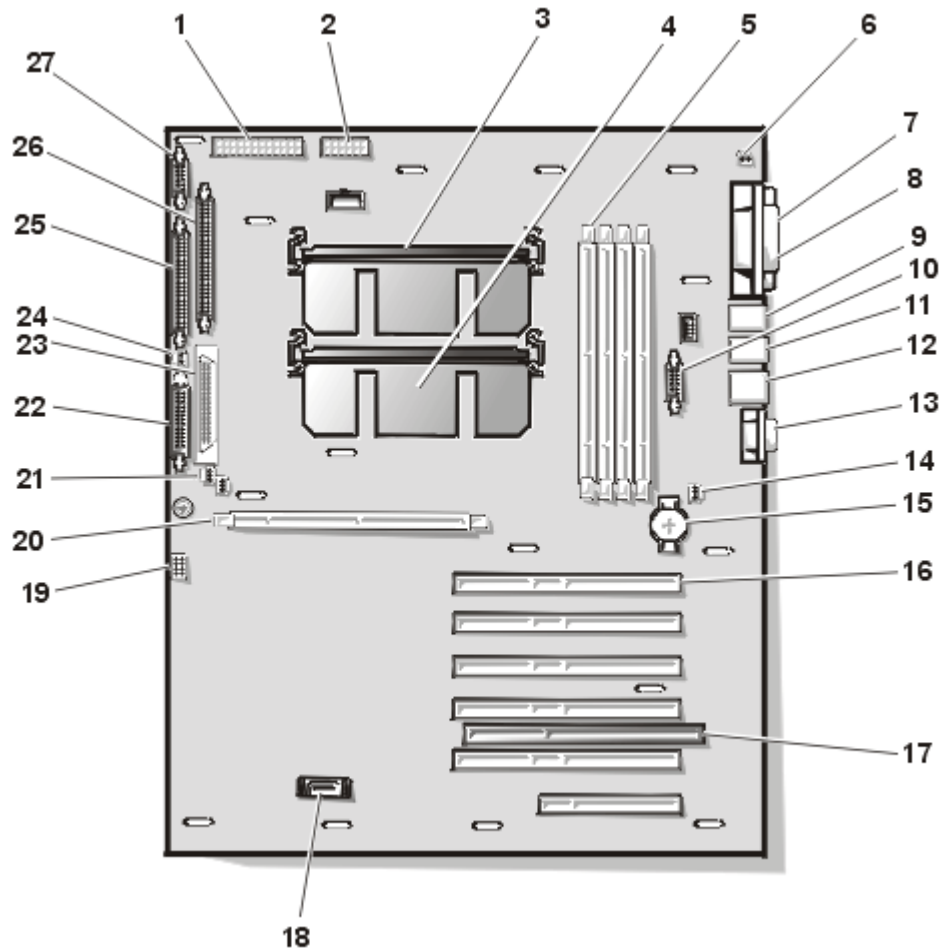

Figure 8-1. System Board Features

-
- 1 Power input connector (POWER1)
 - 2 Power input connector (POWER2)
 - 3 Primary microprocessor (PROC_1)
 - 4 Secondary microprocessor (PROC_2)
 - 5 DIMM sockets (DIMM_A [right]–DIMM_D)
 - 6 Chassis intrusion switch connector (unused) (INTRUS1)
 - 7 Parallel port connector (PARALLEL)
 - 8 Serial port connectors (2) (SERIAL1 and SERIAL2)
-

-
- 9 Keyboard and mouse connectors (KYBD/MOUSE)
 - 10 Integrated RAID hardware key connector (RAID_KEY)
 - 11 Universal Serial Bus (USB) connectors (2)
 - 12 Network interface connector (ENET)
 - 13 Video connector (VGA)
 - 14 Fan connector (FAN3)
 - 15 Battery connector (BATTERY)
 - 16 PCI connectors (PCI1 [top] through PCI6)
 - 17 ISA connector (ISA5)
 - 18 Dell Remote Assistant Card connector (SVR_MGT)
 - 19 Configuration jumpers
 - 20 DIMM socket for optional RAID controller (DIMM_RAID)
 - 21 Fan connectors (FAN1, FAN2)
 - 22 SCSI backplane board interface cable connector (BACKPLANE)
 - 23 Ultra2/LVD SCSI connector (SCSI1)
 - 24 Chassis intrusion switch connector (INTRUS2)
 - 25 Diskette-drive interface connector (FLOPPY)
 - 26 Ultra/Narrow SCSI connector (SCSI2)
 - 27 Control panel interface cable connector (PANEL)
-

Expansion Cards

The system board contains five 64-bit 33-megahertz (MHz) Peripheral Component Interconnect (PCI) expansion-card connectors (PCI1 through PCI5), one 32-bit 33-MHz PCI expansion card connector (PCI6), and one Industry-Standard Architecture (ISA) expansion-card connector (ISA5) (see Figure 8-2). Because ISA expansion-card connector shares an expansion slot with expansion-card connector PCI5, you can install a maximum of six expansion cards.

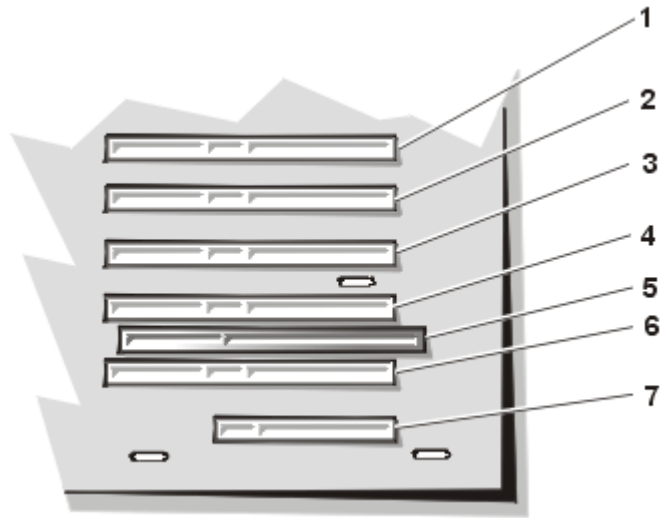

Figure 8-2. Expansion-Card Connectors

-
- | | |
|---|-----------------------------------|
| 1 | PCI expansion-card connector PCI1 |
| 2 | PCI expansion-card connector PCI2 |
| 3 | PCI expansion-card connector PCI3 |
| 4 | PCI expansion-card connector PCI4 |
| 5 | ISA expansion-card connector ISA5 |
| 6 | PCI expansion-card connector PCI5 |
| 7 | PCI expansion-card connector PCI6 |
-

Choosing an Expansion Slot

Follow these guidelines when you add an expansion card:

- Install 64-bit PCI expansion cards in connectors PCI1 through PCI5.
- Install a Dell™ Remote Assistant Card (DRAC), version 2.0, in connector PCI6.
- Install an ISA expansion card in connector ISA5.
- Install full-length expansion cards in PCI slots PCI3 through PCI6 and ISA slot ISA5.

Installing an Expansion Card

Follow this general installation procedure.

NOTICE: You must use the Resource Configuration Utility (RCU) when you add an ISA expansion card to your computer. Failure to do so may cause resource conflicts between PCI devices (such as PCI expansion cards, the built-in video controller, or the built-in small computer system interface [SCSI] host adapter). See Chapter 5, "Using the Resource Configuration Utility," in the *User's Guide* for instructions.

1. If you are installing an ISA expansion card, start the Resource Configuration Utility, and add the new expansion card to the configuration information.

NOTICE: See "Protecting Against Electrostatic Discharge" in the safety instructions.

2. Remove the right-side computer cover.
3. Prepare the expansion card for installation.

See the documentation that came with the expansion card for information on configuring the card, making internal connections, or otherwise customizing the card for the system.

4. Select the expansion slot that you will install the new expansion card in.
5. Open the plastic expansion-card latch and remove the expansion-slot filler bracket:
 - a. Press and hold the plastic tab on the outside of the system chassis.
 - b. Press the release tab on the latch inside the system chassis (see Figure 8-3).
 - c. Open the expansion-card latch (see Figure 8-3) and remove the filler bracket.

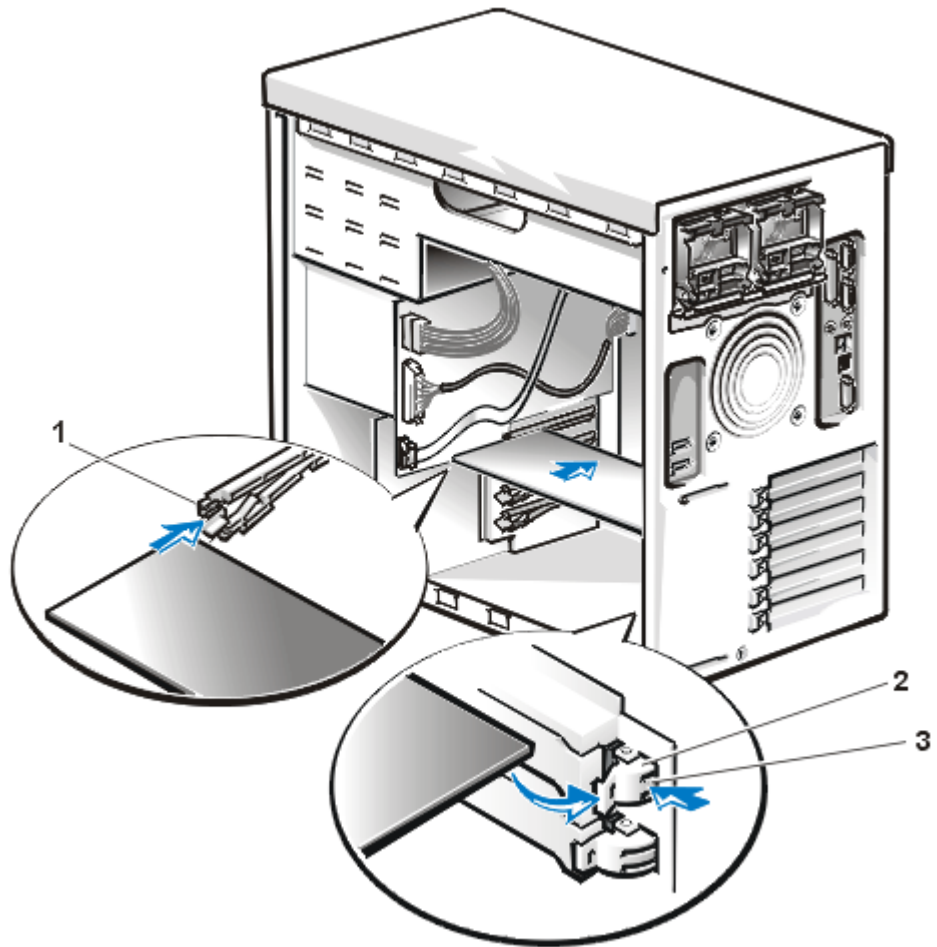

Figure 8-3. Installing an Expansion Card

-
- 1 Plastic card guide
 - 2 Expansion-card latch
 - 3 Release tab on expansion-card latch
-

6. To install the card, insert the card-edge connector firmly into the expansion-card connector on the chassis.
7. When the card is firmly seated in the connector and the card-mounting bracket is aligned with the brackets on either side of it, close the expansion-card latch.

8. If the expansion card is a full-length card, secure the inner end of the card by closing the plastic latch on the card guide over the top edge of the card (see Figure 8-3).
9. Connect any cables that should be attached to the card.

See the documentation that came with the card for information about cable connections.
10. Replace the right-side computer cover, and then reconnect the computer and peripherals to their AC power sources and turn them on.
11. If you installed an ISA expansion card, run the Resource Configuration Utility and add the new expansion card to the configuration. See Chapter 5, "Using the Resource Configuration Utility," in the *User's Guide* for instructions.

Removing an Expansion Card

To remove an expansion card, perform the following steps.

NOTICE: See "Protecting Against Electrostatic Discharge" in the safety instructions.

1. Remove the right-side computer cover.
2. Disconnect any cables connected to the card.
3. To release the expansion card bracket, press and hold the clip on the back of the system while you press the release tab on the latch inside the system (see Figure 8-3), and then rotate the latch away from the expansion-card bracket.
4. If the expansion card is a full-length card, release the card's inner end by opening the tab on the plastic card guide (see Figure 8-3).
5. Grasp the expansion card by its top corners, and carefully remove it from the expansion-card connector.
6. If you are removing the card permanently, install a metal filler bracket over the empty card-slot opening.



NOTE: Installing a filler bracket over an empty expansion slot is necessary to maintain Federal Communications Commission (FCC) certification of the system. The brackets also keep dust and dirt out of the computer and aid in proper cooling and airflow inside the computer.

7. Replace the right-side computer cover, and then reconnect the computer and peripherals to their AC power sources and turn them on.
8. If you are relocating or removing an ISA expansion card, run the Resource Configuration Utility, and delete the expansion card from the configuration information. See Chapter 5, "Using the Resource Configuration Utility," in the *User's Guide* for instructions.

Adding Memory

The four dual in-line memory module (DIMM) sockets on the system board can accommodate 64 megabytes (MB) to 2 gigabyte (GB) of registered synchronous dynamic random-access memory (SDRAM). The DIMM sockets are located near the back edge of the system board (see Figure 8-1).

Memory Upgrade Kits

The system is upgradeable to 2 GB by installing four 512-MB DIMMs. You can purchase memory upgrade kits of 64-, 128-, 256-, and 512-MB registered DIMMs from Dell.



NOTE: The DIMMs must be rated to run at 133 MHz or faster.

DIMM Installation Guidelines

Starting with the socket nearest to the system board's back edge, the DIMM sockets are labeled "DIMM_A" through "DIMM_D" (see Figure 8-4). When you install DIMMs, follow these guidelines:

- Install a DIMM in socket DIMM_A before socket DIMM_B, socket DIMM_B before socket DIMM_C, and so on.
- If you install different sizes of DIMMs, install them in order of descending capacity, beginning with the highest-capacity DIMM in socket DIMM_A.
- You do not need to install DIMMs in pairs.

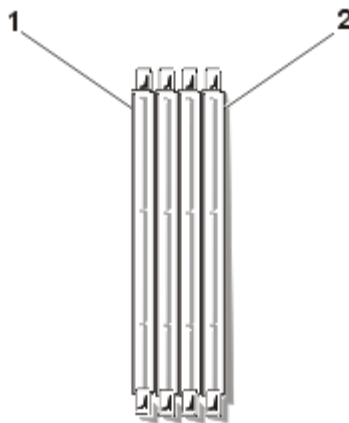

Figure 8-4. DIMM Sockets

1 DIMM_D

2 DIMM_A

Table 8-1 illustrates several sample memory configurations based on these guidelines.

Table 8-1. Sample DIMM Configurations

Total Desired Memory	DIMM Sockets			
	DIMM_A	DIMM_B	DIMM_C	DIMM_D
64 MB	64 MB	None	None	None
128 MB	64 MB	64 MB	None	None
128 MB	128 MB	None	None	None
192 MB	128 MB	64 MB	None	None
512 MB	256 MB	256 MB	None	None
1 GB	256 MB	256 MB	256 MB	256 MB
2 GB	512 MB	512 MB	512 MB	512 MB

Performing a Memory Upgrade

To perform a memory upgrade to the system board, perform the following steps.

NOTICE: See "Protecting Against Electrostatic Discharge" in the safety instructions.

1. Remove the right-side computer cover.
2. Remove the cooling shroud.
3. Locate the DIMM sockets in which you will install or replace DIMMs.

Figure 8-1 shows the relative location of the DIMM sockets on the system board. Figure 8-4 shows the labeling of the DIMMs sockets.

4. Install or replace the DIMMs as necessary to reach the desired memory total.
5. Replace the cooling shroud and computer cover, reconnect the system to the electrical outlet, and turn on the system.

After the system completes the power-on self test (POST) routine, it runs a memory test. The system detects that the new memory does not match the system configuration information, which is stored in nonvolatile RAM (NVRAM). The monitor displays an error message that ends with the following words:

```
Press <F1> to continue; <F2> to enter System Setup
```

6. Press <F2> to enter the System Setup program, and check the **System Memory** setting in the system data box on the System Setup screens. The system should have already changed the value in the **System Memory** setting to reflect the newly installed memory.
7. If the **System Memory** value is incorrect, one or more of the DIMMs may not be installed properly. Repeat steps 1 through 5 again, checking to make sure that the DIMMs are firmly seated in their sockets.
8. Run the Resource Configuration Utility. Then save the configuration and exit the utility.

Running the Resource Configuration Utility and saving the configuration is recommended to ensure that the system will recognize the newly installed DIMM(s). See Chapter 5, "Using the Resource Configuration Utility," in the *User's Guide* for instructions on running the utility and saving the configuration.

9. Run the system memory test in the Dell Diagnostics.

Installing DIMMs

To install a DIMM, perform the following steps:

1. Press down and outward on the ejectors on the DIMM socket, as shown in Figure 8-5, to allow the DIMM to be inserted into the socket.

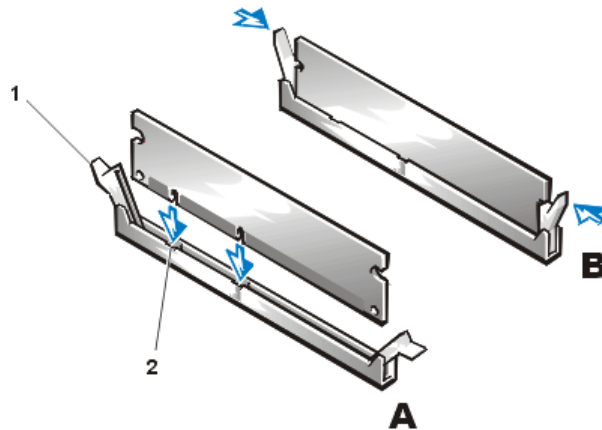

Figure 8-5. Installing a DIMM

1	DIMM socket ejectors (2)	2	Alignment keys (2)
---	--------------------------	---	--------------------

2. Align the DIMM's edge connector with the slot in the center of the DIMM socket, and insert the DIMM in the socket (see step A in Figure 8-5).

The DIMM socket has two alignment keys that allow the DIMM to be installed in the socket in only one way.

3. Press down on the DIMM with your thumbs while pulling up on the ejectors with your index fingers to lock the DIMM into the socket (see step B in Figure 8-5). When the DIMM is properly seated in the socket, the ejectors on the DIMM socket should align with the ejectors on the other sockets with DIMMs installed.
4. Repeat steps 1 through 3 to install the remaining DIMMs.
5. Continue with step 5 of "Performing a Memory Upgrade" found earlier in this chapter.

Removing DIMMs

To remove a DIMM, press down and outward on the ejectors on each end of the socket until the DIMM pops out of the socket (see Figure 8-6).



NOTE: If you encounter difficulty in moving the ejector nearest to the chassis wall, press down on the opposite ejector and lift that end of the DIMM slightly to free the DIMM from its socket.

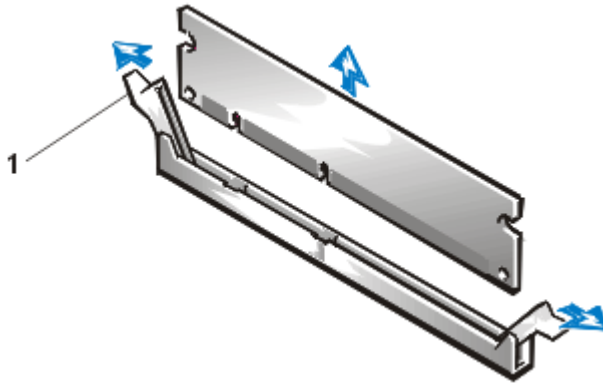

Figure 8-6. Removing a DIMM

1 DIMM socket ejectors (2)

Upgrading the Microprocessor or Installing a Secondary Microprocessor

The microprocessor is contained within a single-edge contact (SEC) cartridge and heat sink assembly. The system board has two guide bracket assemblies, which hold the SEC cartridge and heat sink assemblies. If your system has only one microprocessor, the secondary guide bracket assembly connector must contain a terminator card. If you are adding a microprocessor, the secondary microprocessor must have the same operating frequency as the first. For example, if the system has a 450-MHz primary microprocessor, your secondary microprocessor must also be a 450-MHz microprocessor.

NOTICE: If you are upgrading a system by installing a secondary microprocessor, you must order an upgrade kit from Dell. The upgrade kit from Dell contains the correct version of the microprocessor for use as a secondary microprocessor.

Removing a Terminator Card

To remove a terminator card, perform the following steps.

NOTICE: See "Protecting Against Electrostatic Discharge" in the safety instructions.

1. Remove the right-side computer cover.
2. Remove the cooling shroud.
3. Slide the terminator card up and out of the guide bracket assembly (see Figure 8-7).

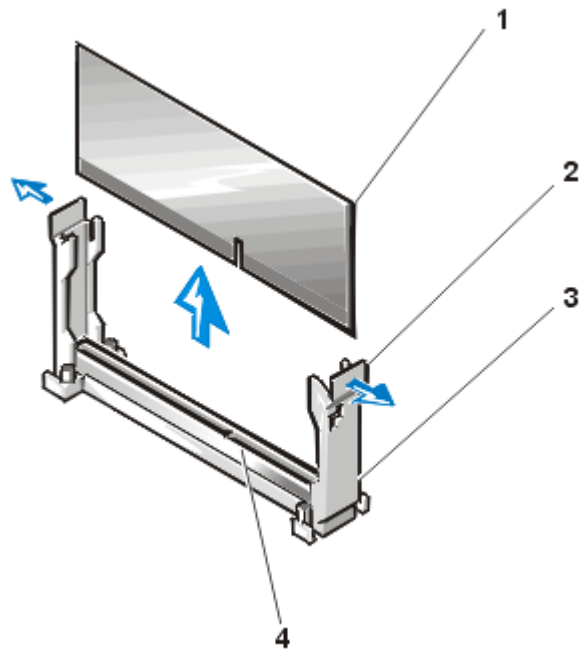

Figure 8-7. Removing a Terminator Card

-
- 1 Terminator card
 - 2 Tabs (2)
 - 3 Guide bracket assembly
 - 4 Socket
-

Installing a Terminator Card

To install a terminator card, align the notch on the terminator card with the socket on the guide bracket assembly and guide the card into the empty guide bracket assembly.

Removing the SEC Cartridge and Heat Sink Assembly

To remove the SEC cartridge and heat sink assembly, perform the following steps.



CAUTION: The SEC cartridge and heat sink assembly can get extremely hot during system operation. Be sure the assembly has had sufficient time to cool before you touch it.



CAUTION: When handling the SEC cartridge and heat sink assembly, take care to avoid sharp edges on the heat sink.

NOTICE: See "Protecting Against Electrostatic Discharge" in the safety instructions.

1. Remove the right-side computer cover.
2. Remove the cooling shroud.
3. Pull the tab on one side of the guide bracket away from the end of the heat sink and pull up slightly on the cartridge.
4. Deflect the tab on the other end of the guide bracket to disengage the tab on the heat sink, and then lift the cartridge and heat sink assembly away from the guide bracket assembly (see Figure 8-8).

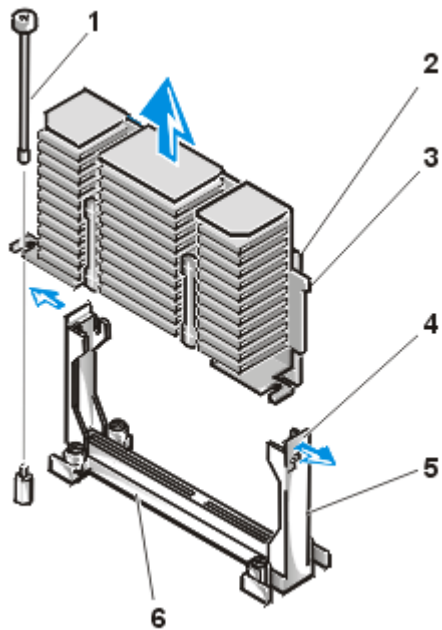

Figure 8-8. Removing an SEC Cartridge and Heat Sink

-
- 1 Retention pin (removed with shroud)
 - 2 SEC cartridge
 - 3 Heat sink
 - 4 Tabs (2)
 - 5 Guide bracket assembly
 - 6 Socket
-

Replacing the SEC Cartridge and Heat Sink Assembly

To install the replacement SEC cartridge and heat sink assembly, perform the following steps:

1. Remove the terminator card or old SEC cartridge from the guide bracket assembly.
2. Slide the SEC cartridge into the guide bracket assembly, and firmly seat the assembly until the tabs on the guide bracket assembly snap into place over the ends of the heat sink (see Figure 8-9).

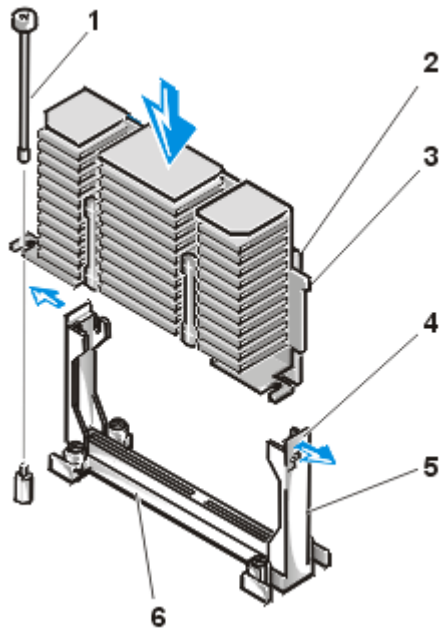

Figure 8-9. Installing an SEC Cartridge and Heat Sink Assembly

-
- 1 Retention pin (installed with shroud)
 - 2 SEC cartridge
 - 3 Heat sink
 - 4 Tabs (2)
 - 5 Guide bracket assembly
 - 6 Socket
-

3. Replace the cooling shroud and computer cover.

Activating the Integrated RAID Controller

To activate the integrated PowerEdge Expandable RAID Controller (PERC) 2/Si controller, perform the following steps.

NOTICE: See "Protecting Against Electrostatic Discharge" in the safety instructions.

1. Remove the right-side computer cover.
2. Remove the cooling shroud.
3. Press the ejectors on the RAID controller DIMM socket down and outward, as shown in Figure 8-5, to allow the DIMM to be inserted into the socket.

See Figure 8-1 for the location of the socket on the system board.

4. Align the DIMM's edge connector with the slot in the center of the DIMM socket, and insert the DIMM in the socket (see step A in Figure 8-5).

The DIMM socket has two alignment keys that allow the DIMM to be installed in the socket in only one way.



NOTE: The RAID controller DIMM must be an unbuffered DIMM, rated to run at 100 MHz or faster. Do not substitute registered DIMMs such as those used for system memory.

5. Press down on the DIMM with your thumbs while pulling up on the ejectors with your index fingers to lock the DIMM into the socket (see step B in Figure 8-5).
6. Install the RAID hardware key in its socket on the system board (see Figure 8-1). Insert the hardware key into the socket and secure the key with the latches on each end of the socket (see Figure 8-10).

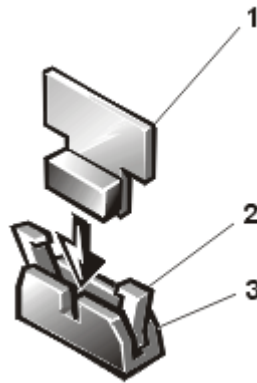

Figure 8-10. Installing the RAID Hardware Key

1 RAID hardware key

2 Latches (2)

3 Socket

7. Replace the cooling shroud and computer cover, and then reconnect the computer and peripherals to their AC power sources and turn them on.
8. Install the RAID software.

For details, refer to the RAID controller documentation.

Replacing the Battery

The system battery maintains system configuration, date, and time information in a special section of memory when you turn off the system. The operating life of the battery ranges from 2 to 5 years, depending on how you use the system (for example, if you keep the system on most of the time, the battery gets little use and thus lasts longer). You may need to replace the battery if an incorrect time or date is displayed during the boot routine along with the following or similar message:

```
Time-of-day not set -- please run SETUP program
Strike the F1 key to continue, F2 to run the setup utility

or
```

```
System CMOS checksum bad -- Run SETUP
Strike the F1 key to continue, F2 to run the setup utility

or
```

```
Invalid configuration information -- please run SETUP program
Strike the F1 key to continue, F2 to run the setup utility
```

To determine if the battery needs replacing, reenter the time and date through the System Setup program. Turn off the system for a few hours, and then turn it on again. Enter the System Setup program. If the date and time are not correct in the System Setup program, replace the battery.



NOTES: Some software may cause the system time to speed up or slow down. If the system seems to operate normally except for the time kept in the System Setup program, the problem may be caused by software rather than by a defective battery.

If the system is turned off for long periods of time (for weeks or months), the NVRAM may lose its system configuration information. This situation is not caused by a defective battery.

You can operate the system without a battery; however, the system configuration information maintained by the battery in NVRAM is erased each time you shut down the computer. Therefore, you must reenter the system configuration information and reset the options each time the system boots until you replace the battery.

The battery is a 3.0-volt (V), coin-cell CR2032-type battery. To remove the battery, perform the following steps.



CAUTION: There is a danger of a new battery exploding if it is incorrectly installed. Replace the battery only with the same or equivalent type recommended by the manufacturer. Discard used batteries according to the manufacturer's instructions.

1. Enter the System Setup program and, if possible, make a printed copy of the System Setup screens.

See Chapter 4, "Using the System Setup Program," in the *User's Guide* for instructions.

2. Shut down the system, including any attached peripherals, and disconnect the system from the electrical outlet.

NOTICE: See "Protecting Against Electrostatic Discharge" in the safety instructions.

3. Remove the right-side computer cover.
4. Remove the cooling shroud.
5. If necessary, remove the expansion cards to gain access to the battery.
6. Remove the battery.

Pry the battery out of its socket with your fingers or with a blunt, nonconductive object such as a plastic screwdriver.

7. Install the new battery with the side labeled "+" facing up (see Figure 8-11).

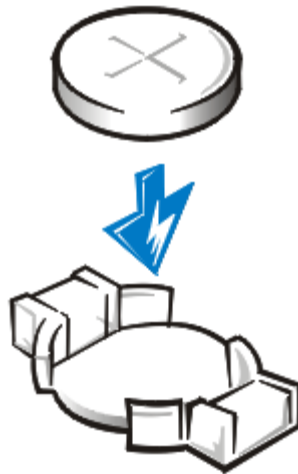
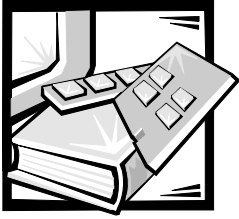

Figure 8-11. Installing the Battery

8. Reinstall the expansion cards if you removed them in step 5.
9. Replace the cooling shroud and computer cover, and then reconnect the computer and peripherals to their AC power sources and turn them on.
10. Enter the System Setup program to confirm that the battery is operating properly.
11. Enter the correct time and date through the System Setup program's **Time** and **Date** settings. Also reenter any system configuration information that is no longer displayed on the System Setup screens, and then exit the System Setup program.
12. Turn off the computer and peripherals, and leave them off for at least an hour.
13. After an hour, turn on the system and enter the System Setup program. If the time and date are still incorrect, see Chapter 11, "Getting Help," for instructions on obtaining technical assistance.



CHAPTER 9

Installing Drives in the External Bays

The external drive bays at the front of a Dell™ PowerEdge™ 2400 system hold up to three user-accessible, half-height 5.25-inch devices (typically CD-ROM or tape drives). A small computer system interface (SCSI) CD-ROM drive is standard in the first external drive bay, while two additional devices of your choice can be installed in the next two external drive bays. External SCSI devices are connected to the Ultra/Narrow SCSI controller on the system board. A fourth drive bay accommodates a standard 3.5-inch diskette drive, which is controlled by the diskette drive controller on the system board. See Figure 9-1 for a general view of the various drives, connector cables, and power cables in the external drive bays.

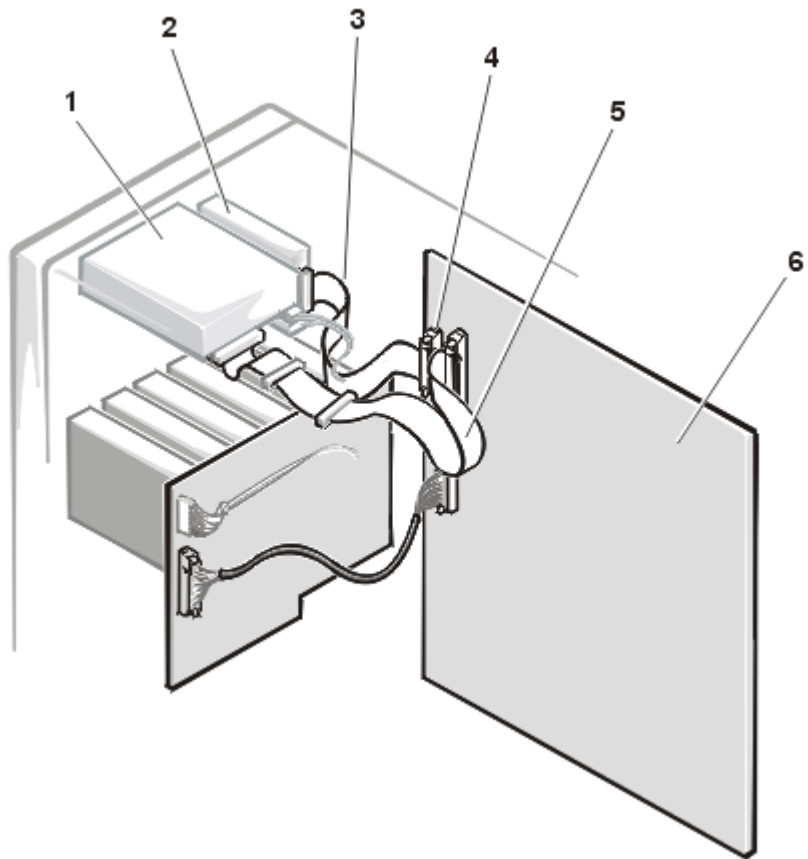

Figure 9-1. External Drive Bay Hardware

-
- 1 SCSI CD-ROM drive
 - 2 Diskette drive
 - 3 Diskette drive interface cable
 - 4 Diskette drive interface connector (FLOPPY)
 - 5 Ultra/Narrow SCSI cable
 - 6 System board
-

Before You Begin

This section describes how to install the following options:

- Drives that use the computer's integrated diskette drive controller
- Drives that use the computer's integrated Ultra/Narrow SCSI controller
- Tape drives that use a controller card



NOTE: If you are installing a SCSI hard-disk drive, see Chapter 10, "Installing Hard-Disk Drives."

To remove or install drives in the external bays, you must remove the computer covers.



WARNING: Before you perform the procedures in this section, you must turn off the computer and disconnect it from its AC power source. For more information, see "Safety First—For You and Your Computer" in Chapter 7.

Removing and Replacing Front-Panel Inserts

To protect the inside of the computer from foreign particles, a plastic insert covers each empty external drive bay. Additionally, each empty external drive bay is covered by a metal insert to maintain the necessary electromagnetic interference (EMI) shielding for the chassis. Before you install a drive in an empty bay, you must first remove the plastic and metal inserts. Whenever you remove a drive, be sure to replace the metal insert on the chassis and then replace the plastic insert in the front bezel to cover the empty bay.

Removing a Plastic Insert

To remove the plastic insert for a drive bay that you intend to use, perform the following steps:

1. Remove the front bezel.
2. Facing the inside of the front bezel, press against the center of the insert with your thumbs until the insert bows sufficiently to loosen the tabs on the sides of the insert.
3. Pull the insert out of the bezel.

Removing a Metal Insert

To remove the metal insert from a drive bay, perform the following steps:

1. Remove the front bezel.
2. Use your thumb to press in the tab on the right edge of the metal insert to release the insert.

3. Pivot the insert away from the chassis and disengage the tab on the insert's left edge.

Connecting the Drive

This section describes the interface cables and power cables used with the drives in your system.

Interface Cables

Most interface connectors are keyed for correct insertion; that is, a notch or a raised tab on one connector matches a tab or a notch on the other connector. Keying ensures that the pin-1 wire in the cable goes to the pin-1 ends of the connectors on both ends.

When you disconnect an interface cable, take care to grasp the cable connector, rather than the cable itself, to avoid stress on the cable.

DC Power Cables

Each drive in the external drive bays must connect to a 4-wire DC power cable from the system power supply. The connectors on these cables are labeled "P3," "P4," "P5," and "P6." Connectors P3, P4, and P5 are used for 5.25-inch devices; connector P6 is used for the 3.5-inch diskette drive.

SCSI Configuration Information

Although SCSI devices are installed essentially the same way as other devices, their configuration requirements are different. To configure SCSI devices installed in the external bays, follow the guidelines in the following subsections.

SCSI ID Numbers

Each device attached to the Ultra/Narrow SCSI host adapter must have a unique SCSI ID number from 0 to 7.

When SCSI devices are shipped from Dell, the default SCSI ID numbers are assigned as follows:

- The integrated Ultra/Narrow SCSI host adapter is configured through the basic input/output system (BIOS) as SCSI ID 7.
- A SCSI tape drive is configured as SCSI ID 6 (the default ID number for a tape drive).
- A SCSI CD-ROM drive is usually configured as SCSI ID 5.



NOTE: There is no requirement that SCSI ID numbers be assigned sequentially or that devices be attached to the cable in order by ID number.

Device Termination

SCSI logic requires that the two devices at opposite ends of the SCSI chain be terminated and that all devices in between be unterminated. The SCSI cable included in your system has an active terminator installed at the end of the cable. Therefore, you should disable the termination on all SCSI devices you attach to this cable.

Installing a SCSI Device

To install a SCSI device that uses the integrated Ultra/Narrow SCSI controller, perform the following steps:

1. Prepare the drive for installation.

NOTICE: See "Protecting Against Electrostatic Discharge" in the safety instructions.

Ground yourself by touching an unpainted metal surface on the back of the computer, unpack the drive, and compare the jumper and switch settings with those in the drive documentation. (See "SCSI Configuration Information" in Chapter 9, "Installing Drives in the External Bays," for information on setting the drive's SCSI ID number and enabling termination [if required].) Change any settings necessary for this system's configuration.

If the drive does not already have drive rails attached, attach a drive rail to each side of the drive and secure each drive rail to the drive with a screw in each of the lower slotted screw holes on the drive rail.

2. Remove the front bezel and right-side computer cover.
3. If other installed drives are in the way, temporarily move them out of the way. Press in on the plastic drive rails at the front of the bay to disengage a drive, and then slide the drive slightly toward the front of the chassis.
4. Remove the metal insert from the drive bay.
5. Slide the new drive into its bay until it snaps securely into place.
If necessary, you can adjust drive alignment by repositioning one or both rails.
6. Plug the DC power cable connector into the 4-pin power input connector on the back of the drive.
7. Select the connector on the Ultra/Narrow SCSI cable that most easily reaches the new SCSI device, and press the interface cable connector firmly onto the drive's interface connector.
8. If you moved other drives in step 3, snap them back into place.
9. Check all cable connections that may have been loosened during this procedure. Arrange cables so that they will not catch on the computer covers or block the airflow of the fans or cooling vents.

10. If a front-panel insert on the front bezel blocks the bay in which you installed the drive, remove the insert.
11. Replace the front bezel and right-side computer cover.
12. Reconnect the computer and peripherals to their AC power sources, and turn them on.
13. Test the SCSI devices.
14. To test a SCSI tape drive, refer to the documentation for the tape drive software to perform a tape drive backup and verification test.

Installing a Tape Drive That Uses a Controller Card

Tape drives that require their own separate controller cards are shipped with the controller card and an interface cable.

To install the drive in an external drive bay, perform the following steps:

1. Configure the controller card if necessary.

Refer to the documentation that came with the tape drive and the card. If the card incorporates jumpers or switches that must be set to work with the system, verify or change the settings as necessary.

NOTICE: See "Protecting Against Electrostatic Discharge" in the safety instructions.

2. Remove the right-side computer cover.
3. If other installed drives are in the way, disengage them by pressing in on the plastic drive rails at the front of the bay, and slide them slightly toward the front of the chassis.
4. Remove the metal insert from the drive bay.
5. Slide the new drive into its bay until it snaps securely into place.
If necessary, you can adjust drive alignment by repositioning one or both rails.
6. Determine which DC power cable connector to use, and then plug the DC power cable connector into the 4-pin power input connector on the back of the drive.
7. Install the controller card in an expansion slot.
8. Attach the interface cable that came with the drive kit to the interface connector on the back of the drive.
9. Connect the interface cable to the controller connector on the controller card.
Refer to the controller card's documentation to identify the controller connector on the card.

10. If you moved other drives in step 3, snap them back into place.
11. Check all cable connections that may have been loosened during this procedure. Arrange cables so that they will not catch on the computer covers or block the air-flow of the fans or cooling vents.
12. If a front-panel insert on the front bezel blocks the bay in which you installed the drive, remove the insert.
13. Replace the front bezel and right-side computer cover.
14. Reconnect the computer and peripherals to their AC power sources, and turn them on.
15. Perform a tape backup and verification test with the drive as instructed in the tape-drive software documentation that came with the drive.

Connecting an External Tape Drive

To connect a stand-alone tape drive that connects to the computer using a controller card and shielded interface/DC power cable, perform the following steps:

1. Prepare the tape drive and controller card for installation.

Ground yourself by touching an unpainted metal surface on the back of the computer. Unpack the tape drive and controller card, and configure them for the system according to the instructions in the documentation that came with the tape drive.

NOTICE: See "**Protecting Against Electrostatic Discharge**" in the safety instructions.

2. Remove the right-side computer cover.
3. Install the controller card in an expansion slot.
4. Replace the computer cover.
5. Connect the tape drive's interface/DC power cable to the external connector on the controller card; secure the connection by tightening the screws on the connector.
6. Reconnect the computer and peripherals to their power sources, and turn them on.
7. Perform a tape backup and verification test with the drive as instructed in the software documentation that came with the drive.

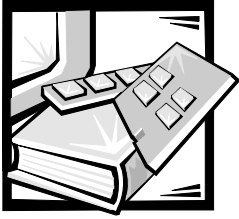

CHAPTER 10

Installing Hard-Disk Drives

This section describes how to install and configure small computer system interface (SCSI) hard-disk drives in the computer's internal hard-disk drive bays. Instructions are also included for upgrading the system by installing a different SCSI backplane board or a Dell™ PowerEdge™ Expandable RAID Controller (PERC) host adapter card.



WARNING: Before you install a new backplane board or host adapter card, you must turn off the computer and disconnect it from its AC power source. For more information, see "Safety First—For You and Your Computer" in Chapter 7.

The hard-disk drive bays provide space for up to four 1.6-inch or six 1-inch hard-disk drives. (See Chapter 9, "Installing Drives in the External Bays," for information on installing SCSI CD-ROM drives and SCSI tape drives in the external drive bays.)

Figure 10-1 illustrates the hard-disk drive bays, the hot-plug SCSI backplane board, and the Ultra2/low voltage differential (LVD) SCSI cable. The Ultra2/LVD SCSI cable has two connectors:

- The connector at one end attaches to the Ultra2/LVD SCSI host adapter connector labeled "SCSI1" on the system board or to an optional SCSI host adapter card such as the Dell PERC 2.
- The connector at the other end of the cable attaches to the connector labeled "SCSIA" on the SCSI backplane board.

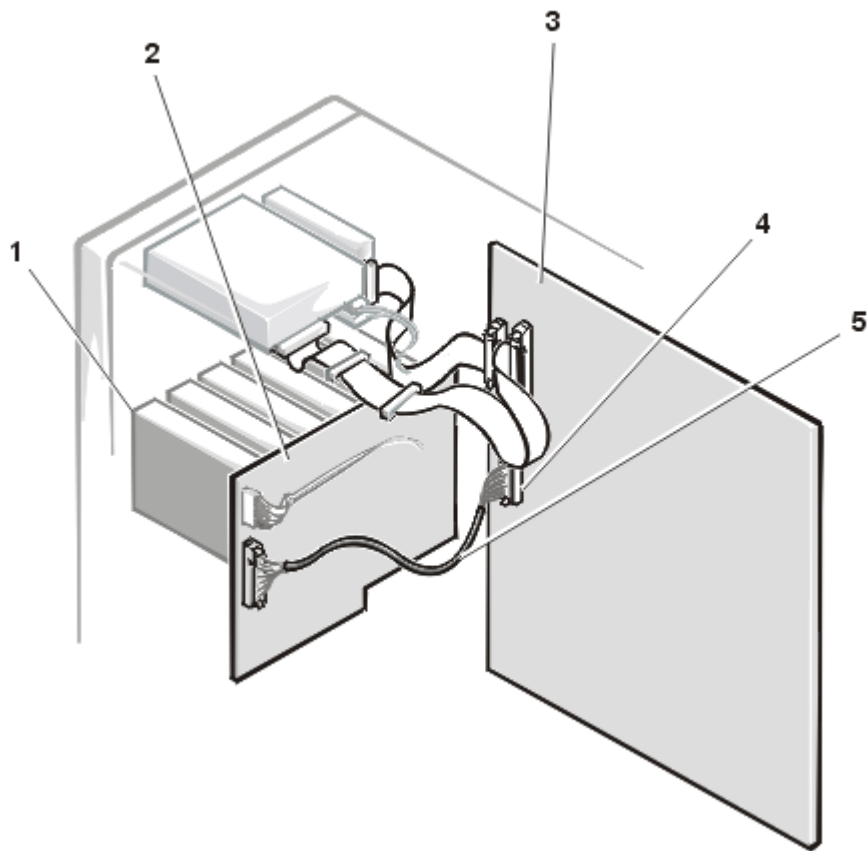

Figure 10-1. Hard-Disk Drive Hardware

-
- 1 SCSI hard-disk drive bays
 - 2 SCSI backplane board
 - 3 System board
 - 4 Ultra2/LVD SCSI host adapter connector (SCSI1)
 - 5 Ultra2/LVD SCSI interface cable
-

Preparing SCSI Hard-Disk Drives for Installation



NOTES: For maximum performance, install Ultra2/LVD drives exclusively. Although you can install a mixture of Ultra2/LVD and Ultra hard-disk drives, they will operate at the slower Ultra transfer rate.

Dell recommends that you use only drives that Dell has tested and approved for use with the SCSI backplane board.

SCSI Hard-Disk Drive Configuration

The SCSI drives must be configured as follows:

- Disable termination on the drives. The SCSI backplane board provides termination for the SCSI bus.
- Set the SCSI ID on all drives to 0. All SCSI ID numbers for the drives are set by the SCSI backplane board (the rightmost drive is set to SCSI ID 0).
- Configure the drives so that the drive motor waits for a Start Unit command from the SCSI host adapter before spinning.

Partitioning and Formatting SCSI Hard-Disk Drives

You may need to use different programs than those provided with the operating system to partition and format SCSI hard-disk drives. See Chapter 3, "Installing and Configuring SCSI Drivers," in the *User's Guide* for information and instructions.

NOTICE: Do not turn off or reboot your system while the drive is being formatted. Turning off or rebooting your system while the drive is being formatted can cause a drive failure.

When you format a high-capacity SCSI hard-disk drive, be sure to allow enough time for the formatting to complete. Long formatting times for these drives are normal. A 9-gigabyte (GB) hard-disk drive, for example, can take up to 2.5 hours to format.

Installing and Removing SCSI Hard-Disk Drives

SCSI hard-disk drives are supplied by Dell in special drive carriers that fit in the hard-disk drive bays.

Installing a SCSI Hard-Disk Drive

To install a SCSI hard-disk drive, perform the following steps.

NOTICE: Hot-plug drive installation is not supported for systems without an integrated RAID controller or Dell PERC 2 host adapter card.

1. If the system does not have a RAID controller installed, shut down the system.
2. Unloc and open the front bezel.

3. For systems with RAID controllers, power down the hard-disk drive bay. If a hard-disk drive is currently installed in the bay, wait until all three SCSI hard-disk drive indicators on the hard-disk drive carrier handle are turned off before proceeding.
4. Open the drive carrier handle and slide the carrier toward you until it is free of the drive bay.
5. Open the handle on the new hard-disk drive carrier.

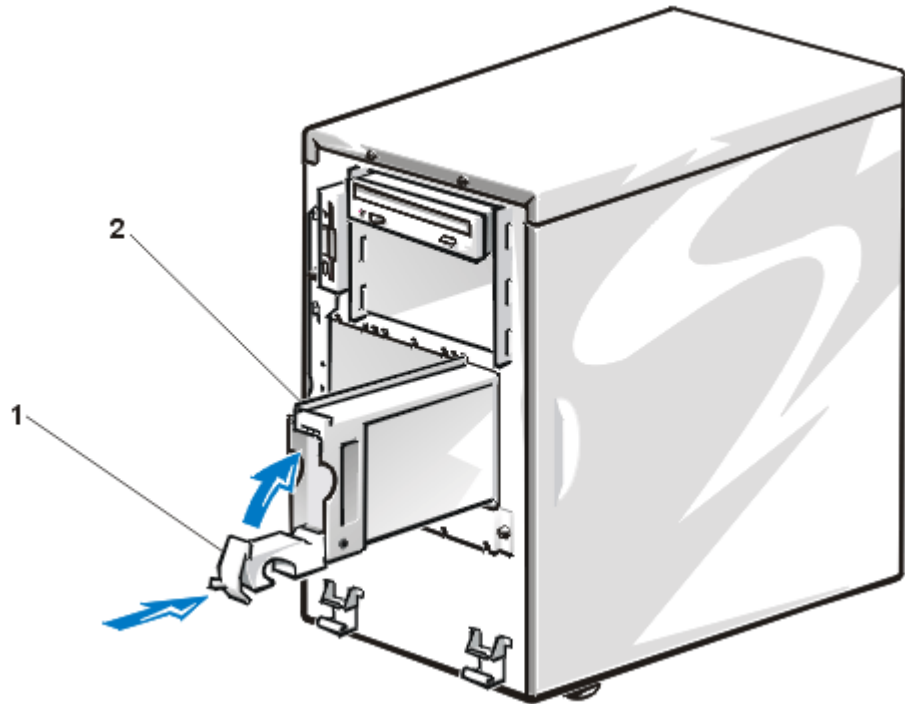

Figure 10-2. Installing a SCSI Hard-Disk Drive Carrier

-
- | | |
|---|--------------------------------|
| 1 | Hard-disk drive carrier handle |
| 2 | Hard-disk drive carrier |
-

6. Align the edge of the carrier with the notches in the hard-disk drive bay keys and insert the carrier into the drive bay (see Figure 2).
7. Close the drive carrier handle to lock the drive in place.
8. Close and lock the front bezel.
9. For systems with RAID controllers, restore power to the drive bay.

10. If the hard-disk drive is a new drive, run the Dell Diagnostics to test the new drive.

Removing a SCSI Hard-Disk Drive

To remove a SCSI hard-disk drive, perform the following steps.

NOTICE: Hot-plug drive removal is not supported for systems without a PERC 2/Si integrated RAID controller or PERC 2 host adapter card.

1. If the system does not have a RAID controller installed, shut down the system.
2. Open the front bezel.
3. For systems with RAID controllers, power down the hard-disk drive bay and wait until the SCSI hard-disk drive indicator codes on the drive carrier signal that the drive may be removed safely.

When all indicators are turned off, the drive is ready for removal.

4. Open the drive carrier handle to release the carrier.
5. Slide the carrier toward you until it is free of the drive bay.
6. Close the front bezel.

Installing a Dell PowerEdge Expandable RAID Controller Host Adapter Card

Follow these general guidelines when you install a Dell host adapter card. For specific instructions, refer to the documentation supplied with the PERC host adapter card.



WARNING: Before you install the host adapter card, you must turn off the computer and disconnect it from the electrical outlet. For more information, see "Safety First—For You and Your Computer."

NOTICE: See "Protecting Against Electrostatic Discharge" in the safety instructions.

1. Unpack the host adapter card and prepare it for installation.

Refer to the documentation accompanying the host adapter card.
2. Remove the right side computer cover.
3. Install the host adapter card.
4. Detach the interface cable from the Ultra2/LVD SCSI host adapter connector on the system board (labeled "SCSI1") (see Figure 8-1 for the location of this connector).

5. Connect the end of the Ultra2/LVD SCSI interface cable to the connector on the host adapter card.

To identify the correct connector, refer to documentation for the host adapter card.



NOTE: If you will be attaching external SCSI devices using the external SCSI connection slots on the computer's back panel, perform steps 6 through 8; otherwise, go to step 9.

6. Connect the SCSI external access cable from the host adapter kit to the Ultra2/LVD SCSI host adapter connector (labeled "SCSI1") on the system board.
7. Attach the other end of the SCSI external access cable to the computer's back panel.

8. If you are attaching multiple external SCSI devices, daisy-chain the devices to each other using the cables shipped with each device.

See each device's documentation for information on cabling that device as part of a daisy chain.

9. Replace the computer cover, and then reconnect the computer and peripherals to their AC power sources.

10. Connect the external SCSI device(s) to electrical outlet(s).

For each external device, plug the socket end of the power cable into the power receptacle on the back of the device. Plug the other end of the power cable into an electrical outlet.

11. Install any required SCSI device drivers.

See Chapter 3, "Installing and Configuring SCSI Drivers," in the *User's Guide* for information and instructions.

12. Test the SCSI devices.

Test a SCSI hard-disk drive by running the Dell Diagnostics. To test a SCSI tape drive, also refer to the documentation for the tape drive software to perform a tape drive backup and verification test.

Installing a SCSI Backplane Board

To replace a SCSI backplane board with a different backplane board, perform the following steps.

NOTICE: See "Protecting Against Electrostatic Discharge" in the safety instructions.

1. Unpack the SCSI backplane board upgrade kit.
2. Remove the right-side computer cover.

NOTICE: You must remove all hard-disk drives to avoid damaging the SCSI backplane board when you remove it later in this procedure.

3. Remove the hard-disk drives from the system.
4. Disconnect the Ultra2/LVD SCSI cable labeled "BACKPLANE" from the SCSI backplane board.

To avoid damage to the cable, use the strain-relief loop to disconnect the cable.

5. Disconnect the data cable labeled "PLANAR" from the backplane board.
6. Disconnect the power cable labeled "PWR2" from the power connector on the backplane board.

To release the connector, press the latch on the side of the connector.

7. Loosen the captive thumbscrew on the backplane board.
8. Slide the existing SCSI backplane board away from the system board approximately 1 cm (a quarter inch), and then lift the board off of the L-shaped mounting tabs and away from the chassis.
9. Are you installing a SCSI backplane with a different number of drive slots?

Yes. Go to step 10.

No. Go to step 12.

10. Remove the hard-disk drive bay key from the front of the system chassis by removing the three screws securing it to the chassis.
11. Reverse the orientation of the drive bay key so that the number of slots on the key's upper edge match the drive capacity of the new backplane, and reinstall the key using the three screws you removed in the previous step.
12. Install the new backplane board (see Figure 10-3):
 - a. While holding the backplane board by its edges, position the board so that the eight tabs on the computer chassis wall fit through the corresponding slots in the backplane board.
 - b. Slide the backplane board toward the system board.
 - c. Secure the backplane board by tightening the captive screw.

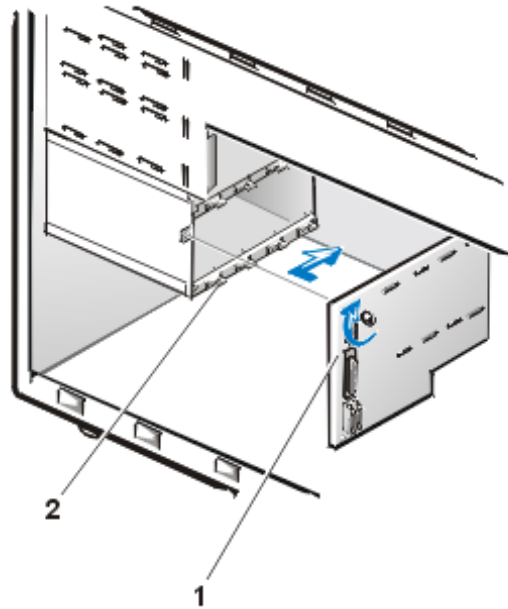

Figure 10-3. Installing a SCSI Backplane Board

-
- 1 SCSI backplane board
 - 2 Tabs (8)
-

13. Connect the 20-pin data cable leading from the system board to the connector labeled "PLANAR" on the backplane board (see Figure10-4).

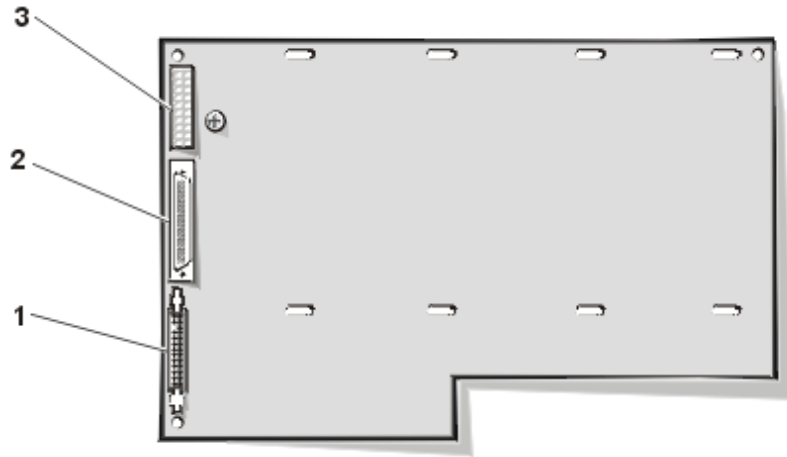

Figure 10-4. SCSI Backplane Board

-
- 1 System-board data cable connector (PLANAR)
 - 2 Ultra2/LVD SCSI cable connector (SCSIA)
 - 3 Power connector (POWER)
-

14. Connect the power cable labeled "PWR2" to the connector labeled "POWER" on the backplane board.
15. Connect the Ultra2/LVD SCSI cable leading from the system board to the connector labeled "SCSIA" on the backplane board.
16. Reinstall the hard-disk drives in the computer.



NOTE: The 1 x 6 SCSI backplane board accommodates only 1-inch hard-disk drives. Do not attempt to reinstall 1.6-inch hard-disk drives if you install a 1 x 6 backplane.

Configuring the Boot Device

If you plan to boot the system from a hard-disk drive, the drive must be attached to the primary (or boot) controller or SCSI host adapter card. You can select the primary controller using the System Setup program. See Chapter 4, "Using the System Setup Program," in the *User's Guide* for instructions.



CHAPTER 11

Getting Help

Technical Assistance

If you need assistance with a technical problem, perform the following steps:

1. Complete the troubleshooting checks in Chapter 6, "Checking the Equipment," and Chapter 7, "Checking Inside the Computer."
2. Run the Dell™ Diagnostics.
3. Make a copy of the Diagnostics Checklist and fill it out.
4. Use Dell's extensive suite of online services available at Dell's World Wide Web site (<http://www.dell.com>) for help with installation and troubleshooting procedures.
5. If the preceding steps have not resolved the problem and you need to talk to a Dell technician, call Dell's technical support service.

When prompted by Dell's automated telephone system, enter your Express Service Code to route the call directly to the proper support personnel. If you do not have an Express Service Code, open the **Dell Accessories** folder, double-click the **Express Service Code** icon, and follow the directions.



NOTE: Dell's Express Service Code system may not be available in all countries.

For instructions on using the technical support service, see "Technical Support Service" and "Before You Call" and then call the number for your country as listed in "Dell Contact Numbers" found later in this chapter.

Help Tools

Dell provides a number of tools to assist you. These tools are described in the following sections.



NOTE: Some of the following tools are not always available in all locations outside the continental U.S. Please call your local Dell representative for information on availability.

World Wide Web on the Internet

The Internet is your most powerful tool for obtaining information about your computer and other Dell products. Through the Internet, you can access most of the services described in this section, including AutoTech, TechFax, order status, technical support, and product information.



From Dell's World Wide Web home page (<http://www.dell.com>), click the **Support** icon, and click **Support Your Dell**. Enter your service tag number (or, if you have one, your Express Service Code) and click **Submit**. If you do not have your service tag number or Express Service Code available, you can also select support information by system.

Everything you need to know about your system is presented on the system support page, including the following tools and information:

- Technical information — Details on every aspect of your system, including hardware specifications.
- Self-diagnostic tools — A system-specific troubleshooting application for resolving many computer-related issues by following interactive flowcharts.
- Drivers, files, and utilities — The latest drivers and basic input/output system (BIOS) updates to keep your system functioning at its best.
- Component support — Technical information, documentation, and troubleshooting tips for different system components.
- Online communications center — Tool for submitting requests for both technical and nontechnical information on Dell products. Avoid telephone delays by receiving an e-mail response to your request for information if your computer is not functioning properly or if you have questions regarding your computer's hardware or operation.

You can contact Dell electronically using the following addresses:

- World Wide Web
<http://www.dell.com>
<http://www.dell.com/ap> (for Asian/Pacific countries only)
<http://euro.dell.com> (for Europe only)
- Anonymous file transfer protocol (FTP)
<ftp.dell.com/>
Log in as `user: anonymous`, and use your e-mail address as your password.
- Electronic Support Service
support@us.dell.com
apsupport@dell.com (for Asian/Pacific countries only)
support.euro.dell.com (for Europe only)

- Electronic Quote Service
sales@dell.com
apmarketing@dell.com (for Asian/Pacific countries only)
- Electronic Information Service
info@dell.com

AutoTech Service

Dell's automated technical support service—AutoTech—provides recorded answers to the questions most frequently asked by Dell customers.

When you call AutoTech, you use your touch-tone telephone to select the subjects that correspond to your questions. You can even interrupt an AutoTech session and continue the session later. The code number that the AutoTech service gives you allows you to continue your session where you ended it.

The AutoTech service is available 24 hours a day, seven days a week. You can also access this service through the technical support service. For the telephone number to call, see "Dell Contact Numbers" found later in this chapter.

TechFax Service

Dell takes full advantage of fax technology to serve you better. Twenty-four hours a day, seven days a week, you can call the Dell TechFax line toll-free for all kinds of technical information.

Using a touch-tone phone, you can select from a full directory of topics. The technical information you request is sent within minutes to the fax number you designate. For the TechFax telephone number to call, see the contact numbers for your region.

TechConnect BBS

Use your modem to access Dell's TechConnect bulletin board service (BBS) 24 hours a day, seven days a week. The service is menu-driven and fully interactive. The protocol parameters for the BBS are 1200 to 19.2K baud, 8 data bits, no parity, 1 stop bit.

Automated Order-Status System

You can call this automated service to check on the status of any Dell products that you have ordered. A recording prompts you for the information needed to locate and report on your order. For the telephone number to call, see "Dell Contact Numbers."

Technical Support Service

Dell's industry-leading hardware technical support service is available 24 hours a day, seven days a week, to answer your questions about Dell hardware.

Our technical support staff pride themselves on their track record: more than 90 percent of all problems and questions are taken care of in just one toll-free call, usually in less than 10 minutes. When you call, our experts can refer to records kept on your Dell system to better understand your particular question. Our technical support staff use computer-based diagnostics to provide fast, accurate answers to questions.

To contact Dell's technical support service, see "Before You Call" and then call the number for your country as listed in "Dell Contact Numbers" found later in this chapter.

Problems With Your Order

If you have a problem with your order, such as missing parts, wrong parts, or incorrect billing, contact Dell Computer Corporation for customer assistance. Have your invoice or packing slip handy when you call. For the telephone number to call, see "Dell Contact Numbers."

Product Information

If you need information about additional products available from Dell Computer Corporation, or if you would like to place an order, visit Dell's World Wide Web site at <http://www.dell.com>. For the telephone number to call to speak to a sales specialist, see "Dell Contact Numbers."

Returning Items for Warranty Repair or Credit

Prepare all items being returned, whether for repair or credit, as follows:

1. Call Dell to obtain an authorization number, and write it clearly and prominently on the outside of the box.
2. Include a copy of the invoice and a letter describing the reason for the return.
3. Include a copy of the Diagnostics Checklist indicating the tests you have run and any error messages reported by the Dell Diagnostics.
4. Include any accessories that belong with the item(s) being returned (power cables, software diskettes, guides, and so on) if the return is for credit.
5. Pack the equipment to be returned in the original (or equivalent) packing materials.

You are responsible for paying shipping expenses. You are also responsible for insuring any product returned, and you assume the risk of loss during shipment to Dell Computer Corporation. Collect On Delivery (C.O.D.) packages are not accepted.

Returns that are missing any of the preceding requirements will be refused at our receiving dock and returned to you.

Before You Call



NOTE: Have your Express Service Code ready when you call. The code helps Dell's automated-support telephone system direct your call more efficiently.

Remember to fill out the Diagnostics Checklist. If possible, turn on your system before you call Dell for technical assistance and call from a telephone at or near the computer. You may be asked to type some commands at the keyboard, relay detailed information during operations, or try other troubleshooting steps possible only at the computer system itself. Make sure the system documentation is available.



WARNING: If you need to remove the computer covers, be sure to first disconnect the computer system's power and modem cables from all electrical outlets.

Diagnostics Checklist

Before you contact Dell, copy this checklist and fill in the service tag and other fields.

Diagnostics Checklist

Name: _____ Date: _____

Address: _____ Phone number: _____

Service tag (bar code on the back of the computer): _____

Express Service Code: _____

Return Material Authorization Number (if provided by Dell support technician): _____

Operating system and version: _____

Peripherals: _____

Expansion cards: _____

Are you connected to a network? yes no

Network, version, and network card: _____

Programs and versions: _____

Refer to your operating system documentation to determine the contents of the system's start-up files. If the computer is connected to a printer, print each file. Otherwise, record the contents of each file before calling Dell.

Error message, beep code, or diagnostic code: _____

Description of problem and troubleshooting procedures you performed: _____

Figure 11-1. Diagnostics Checklist

Dell Contact Numbers

When you need to contact Dell, use the telephone numbers, codes, and electronic addresses provided in the following sections. "International Dialing Codes" provides the various codes required to make long-distance and international calls. "Americas Contact Numbers," "Europe Contact Numbers," and "Asia and Other Regions Contact Numbers" provide local telephone numbers, area codes, toll-free numbers, and e-mail addresses, if applicable, for each department or service available in various countries around the world.

If you are making a direct-dialed call to a location outside of your local telephone service area, determine which codes to use (if any) in "International Dialing Codes," in addition to the local numbers provided in the other sections.

For example, to place an international call from Paris, France to Bracknell, England, dial the international access code for France followed by the country code for the U.K., the city code for Bracknell, and then the local number as shown in the following illustration:

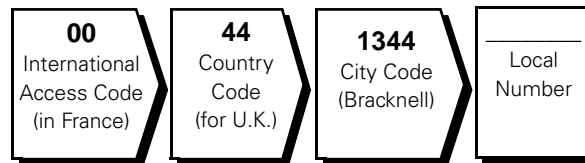

To place a long-distance call within your own country, use area codes instead of international access codes, country codes, and city codes. For example, to call Paris, France from Montpellier, France, dial the area code plus the local number as shown in the following illustration:

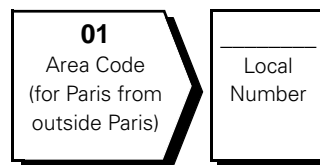

The codes required depend on where you are calling from as well as the destination of your call; in addition, each country has a different dialing protocol. If you need assistance in determining which codes to use, contact a local or an international operator.



NOTES: Toll-free numbers are for use only within the country for which they are listed. Area codes are most often used to call long distance within your own country (not internationally)—in other words, when your call originates in the same country you are calling.

Have your Express Service Code ready when you call. The code helps Dell's automated-support telephone system direct your call more efficiently.

International Dialing Codes

Table 11-1. International Dialing Codes

Country (City)	International Access Code	Country Code	City Code
Australia (Sydney)	0011	61	2
Austria (Vienna)	900	43	1
Belgium (Brussels)	00	32	2
Brunei	—	673	—
Canada (North York, Ontario)	011	—	Not required
Chile (Santiago)	—	56	2
China (Xiamen)	—	86	592
Czech Republic (Prague)	00	420	2
Denmark (Horsholm)	009	45	Not required
Finland (Helsinki)	990	358	9
France (Paris) (Montpellier)	00	33	(1) (4)
Germany (Langen)	00	49	6103
Hong Kong	001	852	Not required
Ireland (Bray)	16	353	1
Italy (Milan)	00	39	2
Japan (Kawasaki)	001	81	44
Korea (Seoul)	001	82	2
Luxembourg	00	352	—
Macau	—	853	Not required
Malaysia (Penang)	00	60	4
Mexico (Colonia Granada)	95	52	5
Netherlands (Amsterdam)	00	31	20
New Zealand	00	64	—
Norway (Lysaker)	095	47	Not required
Poland (Warsaw)	011	48	22
Singapore (Singapore)	005	65	Not required

Table 11-1. International Dialing Codes (continued)

Country (City)	International Access Code	Country Code	City Code
South Africa (Johannesburg)	09/091	27	11
Spain (Madrid)	07	34	91
Sweden (Upplands Vasby)	009	46	8
Switzerland (Geneva)	00	41	22
Taiwan	002	886	—
Thailand	001	66	—
U.K. (Bracknell)	010	44	1344
U.S.A. (Austin, Texas)	011	1	Not required

Table 11-2. Dell Contact Numbers

Country (City)	Department Name or Service	Area Code	Local Number or Toll-Free Number
Australia (Sydney)	Customer Technical Support (Dell™ Dimension™ systems only)		1-300-65-55-33
	Customer Technical Support (Other systems)		toll free: 1-800-633-559
	Customer Care		toll free: 1-800-819-339
	Corporate Sales		toll free: 1-800-808-385
	Transaction Sales		toll free: 1-800-808-312
	Fax		toll free: 1-800-818-341
Austria (Vienna) <i>NOTE: Customers in Austria call Langen, Germany for Technical Support and Customer Care.</i>	Home/Small Business Sales	01795 567602
	Home/Small Business Fax	01795 67605
	Home/Small Business Customer Care	01795 67603
	Preferred Accounts/Corporate Customer Care		0660 8056
	Home/Small Business Technical Support	01795 67604
	Preferred Accounts/Corporate Technical Support		0660 8779
	Switchboard	01	491 04 0
	Web site: http://support.euro.dell.com/at E-mail: tech_support_germany@dell.com		

Table 11-2. Dell Contact Numbers (continued)

Country (City)	Department Name or Service	Area Code	Local Number or Toll-Free Number
Belgium * (Brussels)	Technical Support	02	481 92 88
	Customer Care	02	481 91 19
	Home/Small Business Salestoll free: 0800 16884
	Corporate Sales	02	481 91 00
	Fax	02	481 92 99
	Switchboard	02	481 91 00
	Web site: http://support.euro.dell.com/be E-mail: tech_be@dell.com		
Brunei <i>NOTE: Customers in Brunei call Malaysia for sales, customer, and technical assistance.</i>	Customer Technical Support (Penang, Malaysia)		810 4966
	Customer Service (Penang, Malaysia)		810 4949
	Transaction Sales (Penang, Malaysia).		810 4955
Canada (North York, Ontario) <i>NOTE: Customers in Canada call the U.S.A. for access to TechConnect BBS.</i>	Automated Order-Status Systemtoll free: 1-800-433-9014
	AutoTech (Automated technical support)toll free: 1-800-247-9362
	Customer Care (From outside Toronto)toll free: 1-800-387-5759
	Customer Care (From within Toronto)	416758-2400
	Customer Technical Supporttoll free: 1-800-847-4096
	Sales (Direct Sales—from outside Toronto)toll free: 1-800-387-5752
	Sales (Direct Sales—from within Toronto)	416758-2200
	Sales (Federal government, education, and medical)toll free: 1-800-567-7542
	Sales (Major Accounts)toll free: 1-800-387-5755
	TechConnect BBS (Austin, Texas, U.S.A.)	512728-8528
TechFaxtoll free: 1-800-950-1329	
Chile (Santiago) <i>NOTE: Customers in Chile call the U.S.A for sales, customer, and technical assistance.</i>	Sales, Customer Support, and Technical Supporttoll free: 1230-020-4823

Table 11-2. Dell Contact Numbers (continued)

Country (City)	Department Name or Service	Area Code	Local Number or Toll-Free Number
China (Xiamen)	Customer Service		toll free: 800 858 2437
	Sales		toll free: 800 858 2222
Czech Republic (Prague)	Technical Support	02	22 83 27 27
	Customer Care	02	22 83 27 11
	Fax	02	22 83 27 14
	TechFax	02	22 83 27 28
	Switchboard	02	22 83 27 11
	Web site: http://support.euro.dell.com/cz		
	E-mail: czech_dell@dell.com		
Denmark (Horsholm) <i>NOTE: Customers in Denmark call Sweden for fax technical support.</i>	Technical Support		45170182
	Customer Care		45170181
	Switchboard		45170100
	Fax Technical Support (Upplands Vasby, Sweden)		859005594
	Fax Switchboard		45170117
	Web site: http://support.euro.dell.com/dk		
	E-mail: den_support@dell.com		
Finland (Helsinki)	Technical Support	09	253 313 60
	Technical Support Fax	09	253 313 81
	Customer Care	09	253 313 61
	Fax	09	253 313 99
	Switchboard	09	253 313 00
	Web site: http://support.euro.dell.com/fi		
	E-mail: fin_support@dell.com		

Table 11-2. Dell Contact Numbers (continued)

Country (City)	Department Name or Service	Area Code	Local Number or Toll-Free Number
France (Paris/Montpellier)	Technical Support	0803387 270
	Customer Care (Paris)	0147 62 68 92
	Customer Care (Montpellier)	0467 06 61 96
	TechConnect BBS (Montpellier)	0467 22 53 04
	Fax (Montpellier)	0467 06 60 07
	Switchboard (Paris)	0147 62 69 00
	Switchboard (Montpellier)	0467 06 60 00
Web site: http://support.euro.dell.com/fr			
E-mail: web_fr_tech@dell.com			
Germany (Langen)	Technical Support	06103971-200
	Technical Support Fax	06103971-222
	Home/Small Business Customer Care	06103971-530
	Preferred Accounts Customer Care	06103971-420
	TechConnect BBS	06103971-666
	Switchboard	06103971-0
	Corporate Customer Care	06103971-560
Web site: http://www.dell.de/support			
E-mail: tech_support_germany@dell.com			
Hong Kong <i>NOTE: Customers in Hong Kong call Malaysia for customer assistance.</i>	Technical Support	toll free: 800 96 4107	
	Customer Service (Penang, Malaysia)810 4949	
	Transaction Sales	toll free: 800 96 4109	
	Corporate Sales	toll free: 800 96 4108	

Table 11-2. Dell Contact Numbers (continued)

Country (City)	Department Name or Service	Area Code	Local Number or Toll-Free Number
Ireland (Bray) <i>NOTE: Customers in Ireland call the U.K. for Home/Small Business customer assistance.</i>	Technical Support		1-850-543-543
	Customer Care	01	204 4026
	Home/Small Business Customer Care (Bracknell, U.K.)		0870 906 0010
	Sales		1-850-235-235
	SalesFax	01	286 2020
	Fax	01	286 6848
	TechConnect BBS	01	204 4711
	TechFax	01	204 4708
	Switchboard	01	286 0500
	Web site: http://support.euro.dell.com/ie E-mail: dell_direct_support@dell.com		
Italy (Milan)	Technical Support	2	57782.690
	Customer Care	2	57782.555
	Sales	2	57782.411
	Fax	2	57503530
	Switchboard	2	57782.1
	Web site: http://support.euro.dell.com/it E-mail: support_italy@dell.com		
Japan (Kawasaki)	Technical Support		toll free: 0088-22-7890
	Technical Support (Server)		toll free: 0120-1984-35
	Technical Support (Dimension and Inspiron™)		toll free: 0120-1982-56
	Technical Support (WorkStation, OptiPlex™, and Latitude™)		toll free: 0120-1984-39
	Y2K Support	044	556-4298
	Customer Care	044	556-4240
	Direct Sales	044	556-3344
	Commercial Sales	044	556-3430 556-3440
	Faxbox Service		03-5972-5840
	Switchboard	044	556-4300

Table 11-2. Dell Contact Numbers (continued)

Country (City)	Department Name or Service	Area Code	Local Number or Toll-Free Number
Korea (Seoul) <i>NOTE: Customers in Korea call Malaysia for customer assistance.</i>	Technical Support		toll free: 080-200-3800
	Transaction Sales		toll free: 080-200-3600
	Corporate Sales		toll free: 080-200-3900
	Customer Service (Penang, Malaysia)		810 4949
	Fax		394 3122
Latin America <i>NOTE: Customers in Latin America call the U.S.A. for sales, customer, and technical assistance.</i>	Customer Technical Support (Austin, Texas, U.S.A.)	512	728-4093
	Customer Service (Austin, Texas, U.S.A.)	512	728-3619
	Fax (Technical Support and Customer Service) (Austin, Texas, U.S.A.)	512	728-3883
	Sales (Austin, Texas, U.S.A.)	512	728-4397
	SalesFax (Austin, Texas, U.S.A.)	512	728-4600 728-3772
Luxembourg <i>NOTE: Customers in Luxembourg call Belgium for sales, customer, and technical assistance.</i>	Technical Support (Brussels, Belgium)	02	481 92 88
	Home/Small Business Sales (Brussels, Belgium)		toll free: 080016884
	Corporate Sales (Brussels, Belgium)	02	481 91 00
	Customer Care (Brussels, Belgium)	02	481 91 19
	Fax (Brussels, Belgium)	02	481 92 99
	Switchboard (Brussels, Belgium)	02	481 91 00
Macau <i>NOTE: Customers in Macau call Malaysia for customer assistance.</i>	Technical Support		toll free: 0800 582
	Customer Service (Penang, Malaysia)		810 4949
	Transaction Sales		toll free: 0800 581
Malaysia (Penang)	Technical Support		toll free: 1 800 888 298
	Customer Service	04	810 4949
	Transaction Sales		toll free: 1 800 888 202
	Corporate Sales		toll free: 1 800 888 213

Table 11-2. Dell Contact Numbers (continued)

Country (City)	Department Name or Service	Area Code	Local Number or Toll-Free Number
<p>Mexico (Colonia Granada)</p> <p><i>NOTE: Customers in Mexico call the U.S.A. for access to the Automated Order-Status System and AutoTech.</i></p>	Automated Order-Status System (Austin, Texas, U.S.A.)	512	728-0685
	AutoTech (Automated technical support) (Austin, Texas, U.S.A.)	512	728-0686
	Customer Technical Support	525	228-7870
	Sales	525	228-7811
			toll free: 91-800-900-37
			toll free: 91-800-904-49
	Customer Service Main	525	228-7878 228-7800
<p>Netherlands (Amsterdam)</p>	Technical Support	020	5818838
	Customer Care	020	581 8740
	Home/Small Business Sales		toll free: 0800-0663
	Home/Small Business Sales Fax	020	682 7171
	Corporate Sales	020	581 8818
	Corporate Sales Fax	020	686 8003
	Fax	020	686 8003
	Switchboard	020	581 8818
<p>New Zealand</p>	Technical Support (Dell Dimension systems only) (\$2.50 + GST per call)		0900 51010
	Technical Support (Other systems)		0800 446 255
	Customer Service		0800 444 617
	Sales		0800 441 567
	Fax		0800 441 566
<p>Norway (Lysaker)</p> <p><i>NOTE: Customers in Norway call Sweden for fax technical support.</i></p>	Technical Support		.671 16882
	Customer Care		.671 16881
	Switchboard	67	1 16800
	Fax Technical Support (Upplands Vasby, Sweden)		590 05 594
	Fax Switchboard		.671 16865
	Web site: http://support.euro.dell.com/no E-mail: nor_support@dell.com		

Table 11-2. Dell Contact Numbers (continued)

Country (City)	Department Name or Service	Area Code	Local Number or Toll-Free Number
Poland (Warsaw)	Technical Support Customer Care Sales Fax Switchboard Web site: http://support.euro.dell.com/pl E-mail: pl_support@dell.com	22 22 22 22 22	60 61 999 60 61 999 60 61 999 60 61 998 60 61 999
Singapore (Singapore) <i>NOTE: Customers in Singapore call Malaysia for customer assistance.</i>	Technical Support Customer Service (Penang, Malaysia) Transaction Sales Corporate Sales	toll free: 800 6011 051 04 toll free: 800 6011 054 toll free: 800 6011 053	810 4949
South Africa (Johannesburg)	Technical Support Customer Care Sales Fax Switchboard Web site: http://support.euro.dell.com/za E-mail: dell_za_support@dell.com	011 011 011 011 011	709 7710 709 7710 706 7700 709 0495 709 7700
Southeast Asian/ Pacific Countries (excluding Australia, Brunei, China, Hong Kong, Japan, Korea, Macau, Malaysia, New Zealand, Singapore, Taiwan, and Thailand—refer to individual listings for these countries)	Customer Technical Support, Customer Service, and Sales (Penang, Malaysia)		60 4 810-4810

Table 11-2. Dell Contact Numbers (continued)

Country (City)	Department Name or Service	Area Code	Local Number or Toll-Free Number
Spain (Madrid)	Technical Support Corporate Customer Care Home/Small Business Customer Care TechConnect BBS. 91 Corporate Sales Home/Small Business Sales Switchboard 91 Web site: http://support.euro.dell.com/es E-mail: es_support@dell.com		902 100 130 902 118 546 902 118 540 329 33 53 902 100 185 902 118 541 722 92 00
Sweden (Upplands Vasby)	Technical Support 08 Customer Care 08 Fax Technical Support. 08 Sales. 08 Web site: http://support.euro.dell.com/se E-mail: swe_support@dell.com		590 05 199 590 05 169 590 05 594 590 05 185
Switzerland (Geneva)	Technical Support Customer Care Fax 022 Switchboard 022 Web site: http://support.euro.dell.com/ch E-mail: swisstech@dell.com		0844 811 411 0848 802 802 799 01 90 799 01 01
Taiwan <i>NOTE: Customers in Taiwan call Malaysia for customer assistance.</i>	Technical Support toll free: 0080 651 226/0800 33 557 Customer Service (Penang, Malaysia) 810 4949 Transaction Sales toll free: 0080 651 228/0800 33 556 Corporate Sales toll free: 0080 651 227/0800 33 555		
Thailand <i>NOTE: Customers in Thailand call Malaysia for customer assistance.</i>	Technical Support toll free: 0880 060 07 Customer Service (Penang, Malaysia) 810 4949 Sales. toll free: 0880 060 06		

Table 11-2. Dell Contact Numbers (continued)

Country (City)	Department Name or Service	Area Code	Local Number or Toll-Free Number
U.K. (Bracknell)	Technical Support		0870-908-0800
	Corporate Customer Care	01344	720206
	Home/Small Business Customer Care		0870-906-0010
	TechConnect BBS		0870-908-0610
	Sales	01344	720000
	AutoFax		0870-908-0510
	Web site: http://support.euro.dell.com/uk E-mail: dell_direct_support@dell.com		

Table 11-2. Dell Contact Numbers (continued)

Country (City)	Department Name or Service	Area Code	Local Number or Toll-Free Number	
U.S.A. (Austin, Texas)	Automated Order-Status System		toll free: 1-800-433-9014	
	AutoTech (Automated technical support)		toll free: 1-800-247-9362	
	Dell Home and Small Business Group:	Customer Technical Support (Return Material Authorization Numbers)		toll free: 1-800-624-9896
	Customer Service (Credit Return Authorization Numbers)		toll free: 1-800-624-9897	
	National Accounts (systems purchased by established Dell national accounts [have your account number handy], medical institutions, or value-added resellers [VARs]):	Customer Service and Technical Support (Return Material Authorization Numbers)		toll free: 1-800-822-8965
	Public Americas International (systems purchased by governmental agencies [local, state, or federal] or educational institutions):	Customer Service and Technical Support (Return Material Authorization Numbers)		toll free: 1-800-234-1490
	Dell Sales		toll free: 1-800-289-3355	
			toll free: 1-800-879-3355	
	Spare Parts Sales		toll free: 1-800-357-3355	
	DellWare SM		toll free: 1-800-753-7201	
	DellWare FaxBack Service	512	728-1681	
	Fee-Based Technical Support		toll free: 1-800-433-9005	
	Sales (Catalogs)		toll free: 1-800-426-5150	
	Fax		toll free: 1-800-727-8320	
	TechFax		toll free: 1-800-950-1329	
	TechConnect BBS	512	728-8528	
	Dell Services for the Deaf, Hard-of-Hearing, or Speech-Impaired		toll free: 1-877-DELLTTY (1-877-335-5889)	
	Switchboard		512338-4400	

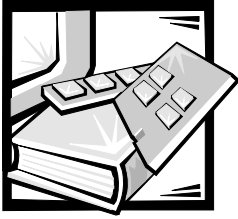

APPENDIX A

Jumpers, Switches, and Connectors

This section provides specific information about the jumpers on the system board. It also provides some basic information on jumpers and switches and describes the connectors and sockets on the various boards in the computer.

Jumpers and Switches—A General Explanation

Jumpers and switches provide a convenient and reversible way of reconfiguring the circuitry on a printed circuit board. When reconfiguring the system, you may need to change jumper settings on the system board. You may also need to change jumper and/or switch settings on expansion cards or drives.

Jumpers

Jumpers are small blocks on a circuit board with two or more pins emerging from them. Plastic plugs containing a wire fit down over the pins. The wire connects the pins and creates a circuit. To change a jumper setting, pull the plug off its pin(s) and carefully fit it down onto the pin(s) indicated.



NOTICE: Make sure the system is turned off before you change a jumper setting. Otherwise, damage to the system or unpredictable results may occur.

A jumper is referred to as open or unjumped when the plug is pushed down over only one pin or if there is no plug at all. When the plug is pushed down over two pins,

the jumper is referred to as jumpered. The jumper setting is often shown in text as two numbers, such as 1-2. The number 1 is printed on the circuit board so that you can identify each pin number based on the location of pin 1.

Figure A-1 shows the location and default settings of the jumper blocks on the system board. See Table A-1 for the designations, default settings, and functions of the system's jumpers.

Switches

Switches control various circuits or functions in the computer system. The switches that you are most likely to encounter are dual in-line package (DIP) switches, which are normally packaged in groups of two or more switches in a plastic case. Two common types of DIP switches are slide switches and rocker switches (see the following illustration).

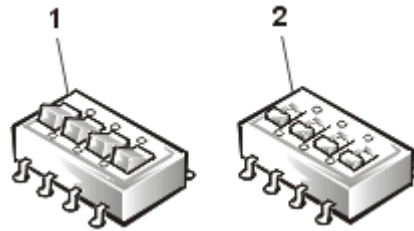

-
- 1 Rocker switch
 - 2 Slide switch
-

Each of these switches has two positions, or settings (usually on and off). To change the setting of a slide switch, use a small, pointed object such as a small screwdriver or a straightened paper clip to slide the switch to the proper position. To change the setting of a rocker switch, use the screwdriver or paper clip to press down on the appropriate side of the switch. In either case, do not use a pen, pencil, or other object that might leave a residue on the switch.

System Board Jumpers

Figure A-1 shows the location of the configuration jumpers on the system board. Table A-1 lists the function of these jumpers.

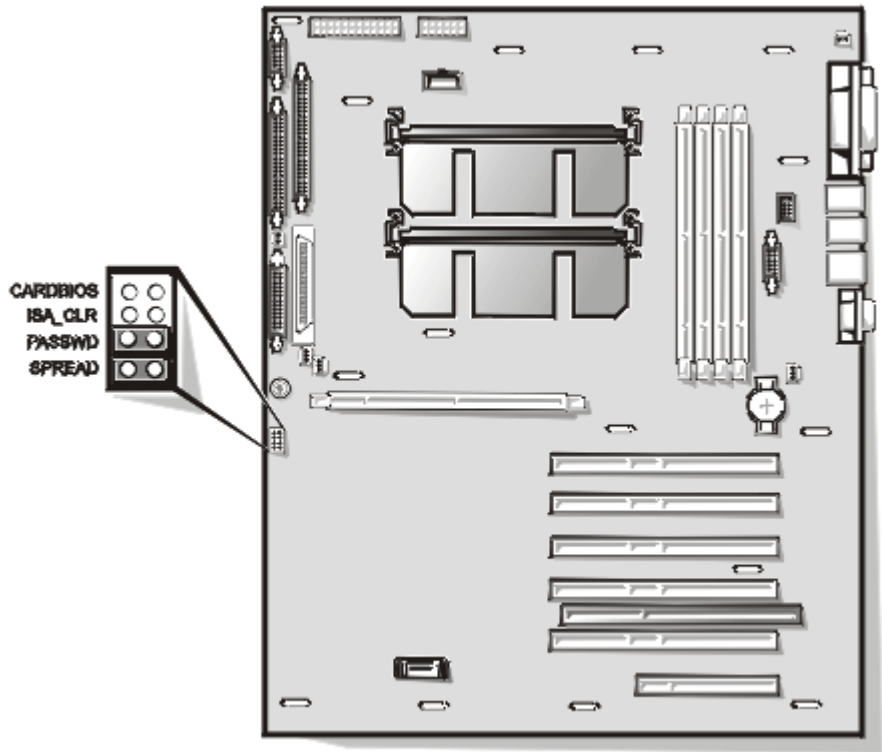

Figure A-1. System Board Jumpers

Table A-1. System-Board Jumper Settings







Jumper	Setting	Description
CARDBIOS		Reserved (do not change).
ISA_CLR	 	(default) The ISA configuration settings are retained at system boot. The ISA configuration settings are cleared at next system boot. (If the ISA configuration settings become corrupted to the point where the system will not boot, install the jumper plug and boot the system. Remove the jumper before restoring the ISA configuration information.)

Table A-1. System-Board Jumper Settings (continued)

Jumper	Setting	Description
PASSWD		(default) The password feature is enabled.
		The password feature is disabled.
SPREAD		Reserved (<i>do not change</i>).

jumpered  unjumpered 

NOTE: For the full name of an abbreviation or acronym used in this table, see "Abbreviations and Acronyms."

System Board Labels

Table A-2 lists the connectors and sockets located on the system board.

Table A-2. System Board Connectors and Sockets

Connector or Socket	Description
BACKPLANE	Hot-pluggable SCSI backplane board interface cable connector
BATTERY	Battery connector
DIMM_x	DIMM sockets
DIMM_RAID	DIMM socket for integrated RAID controller
ENET	Ethernet connector
INTRUS _n	Intrusion-alarm switch connectors
ISA5	ISA expansion-card connector
FAN _n	Fan connectors
FLOPPY	Diskette drive interface connector
KYBD	Keyboard connector
MOUSE	Mouse connector
PANEL	System control panel connector
PARALLEL	Parallel port connector; sometimes referred to as LPT1
PCI _n	PCI expansion-card connectors
POWER _n	Power and power supply status connector
RAID_KEY	Socket for integrated RAID controller hardware key

Table A-2. System Board Connectors and Sockets (continued)

Connector or Socket	Description
SCSI1	Ultra2/LVD SCSI host adapter connector
SCSI2	Ultra/Narrow SCSI host adapter connector
SERIAL n	Serial port connectors; sometimes referred to as COM1 and COM2
SVR_MGT	Connector for DRAC card
USB n	USB connector
VGA	Video connector
PROC_ n	Microprocessor guide bracket assembly and connectors

NOTE: For the full name of an abbreviation or acronym used in this table, see "Abbreviations and Acronyms."

SCSI Backplane Boards

Figure A-2 shows the location of the connectors on the 1 x 6 and 1 x 4 SCSI backplane board.

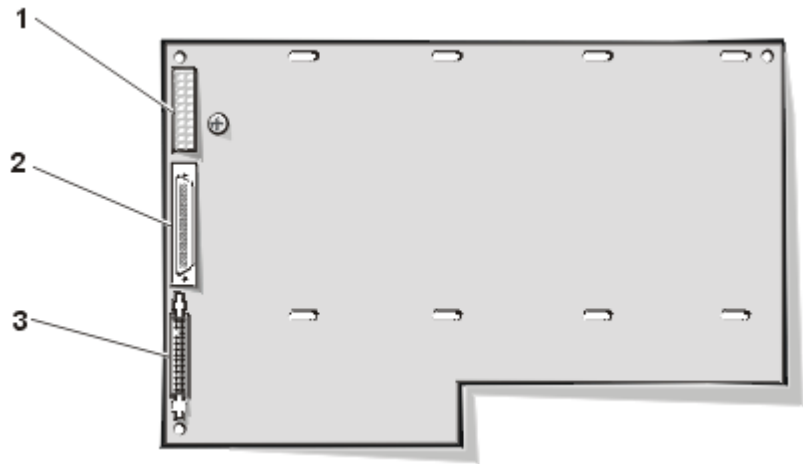

Figure A-2. Connectors on the SCSI Backplane Boards

- | | |
|---|--|
| 1 | Power connector (POWER) |
| 2 | Ultra2/LVD SCSI cable connector (SCSIA) |
| 3 | System-board data cable connector (PLANAR) |

Disabling a Forgotten Password

The computer's software security features include a supervisor password and a user password, which are discussed in detail in Chapter 4, "Using the System Setup Program," in the *User's Guide*. A password jumper on the system board enables these password features or disables them and clears any password(s) currently in use.

To disable a forgotten supervisor password or user password, perform the following steps.

NOTICE: See "Protecting Against Electrostatic Discharge" in the safety instructions.

1. Remove the right-side computer cover.
2. Refer to Figure A-1 for the location of the password jumper (labeled "PASSWD") on the system board.
3. Remove the jumper plug from the PASSWD jumper.
4. Replace the right-side computer cover, and then reconnect the computer to an electrical outlet and turn it on.

The existing passwords are not disabled (erased) until the system boots with the PASSWD jumper plug removed. However, before you assign a new system and/or user password, you must install the jumper plug.



NOTE: If you assign a new system and/or user password with the jumper plug still removed, the system disables the new password(s) the next time it boots.

5. Repeat step 1.
6. Install the jumper plug on the PASSWD jumper.
7. Replace the right-side computer cover, and then reconnect the computer and peripherals to their electrical outlets and turn them on.
8. Assign a new system and/or user password.

To assign a new system password using the System Setup program, see "Assigning a System Password" in Chapter 4 of the *User's Guide*. To assign a new user password using the System Setup program, see "Assigning a User Password" in Chapter 4 of the *User's Guide*.

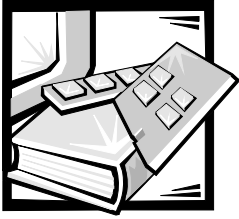

APPENDIX B

Installing Redundant Power Supplies

This section includes instructions on upgrading your system with dual, redundant hot-plug power supplies and a power-supply distribution board (PSDB).



WARNING: Before you perform the procedures in this section, you must turn off the computer and disconnect it from its AC power source. For more information, refer to "Safety First—For You and Your Computer" in Chapter 7.



WARNING: Do not remove the cover from the PSDB. No user-serviceable parts are inside this assembly.

Installing the PSDB

To install a PSDB in the computer, perform the following steps.

NOTICE: See "Protecting Against Electrostatic Discharge" in the safety instructions.

1. Remove the front bezel and both computer covers.
2. Disconnect the AC power cable from the AC power receptacle on the back of the power supply.
3. Remove the two screws at the front edge of the top cover (see Figure B-1).

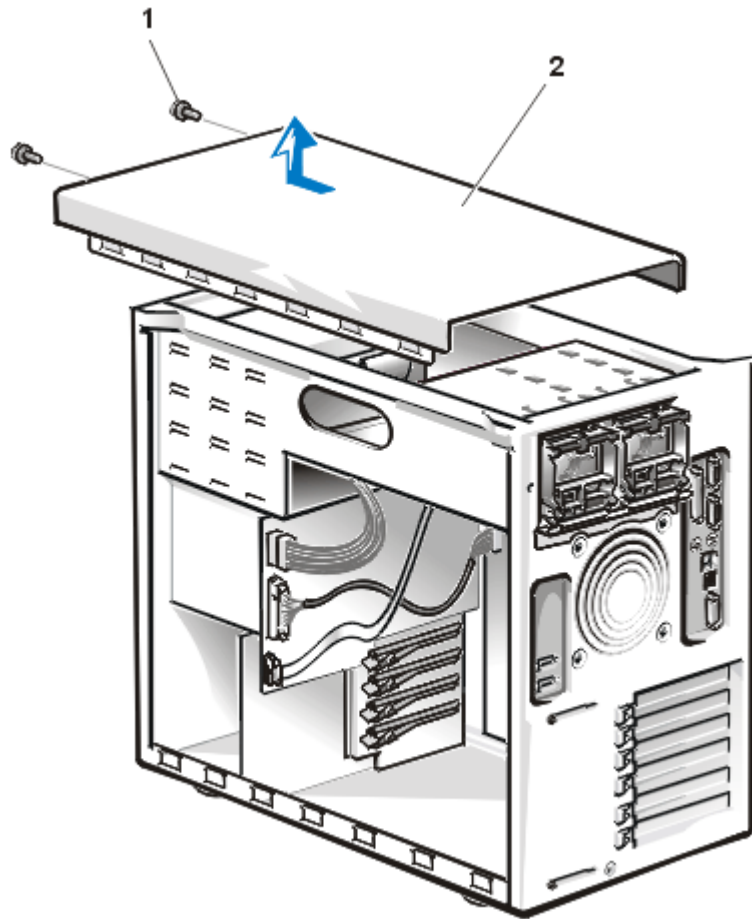

Figure B-1. Removing the Top Cover

1 Screws (2)

2 Top cover

4. Slide the top cover about a half inch toward the front of the computer and lift it away.
5. Disconnect the power cable harness from the POWER connector on the small computer system interface (SCSI) backplane board, the POWER1 connector on the system board, and the diskette drive and other drives in the external drive bays. When you disconnect a cable connector from the SCSI backplane board and the system board, press the plastic latch on one side of the connector to release it.

6. Remove the two screws on either side of the power supply (see Figure B-2).

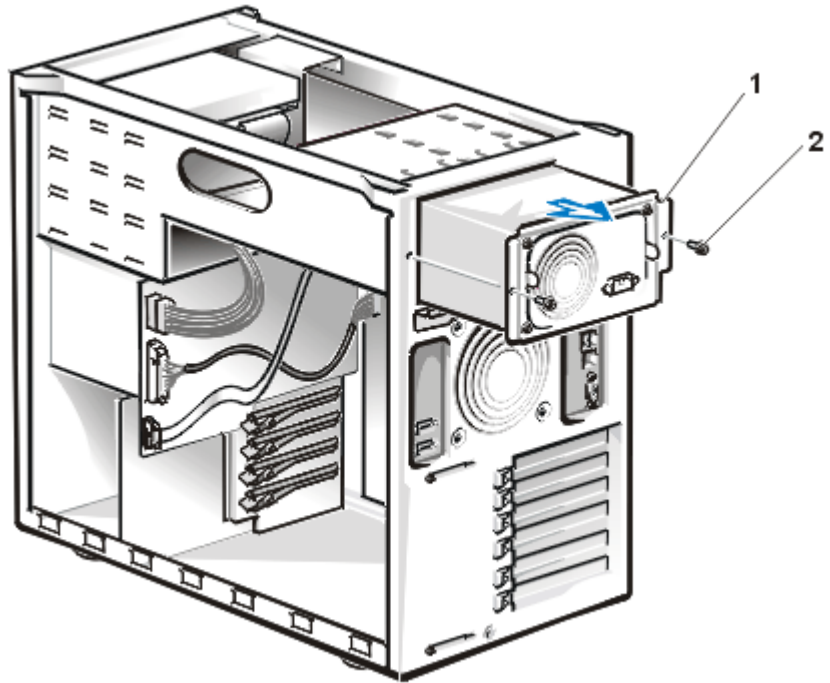

Figure B-2. Removing the Power Supply

-
- | | |
|----------|----------------------------------|
| 1 | Power supply |
| 2 | Power-supply mounting screws (2) |
-

7. Slide the power supply out of the system chassis.
8. Install the PSDB onto the PSDB tray (see Figure B-3):
 - a. While holding the PSDB by its edges, position the PSDB so that the three tabs on the PSDB tray fit through the corresponding slots in the PSDB and the two power supply connectors face towards the back of the chassis.
 - b. Slide the PSDB toward the back of the system about one centimeter (a quarter of an inch).
 - c. Secure the PSDB by tightening the thumbscrew.

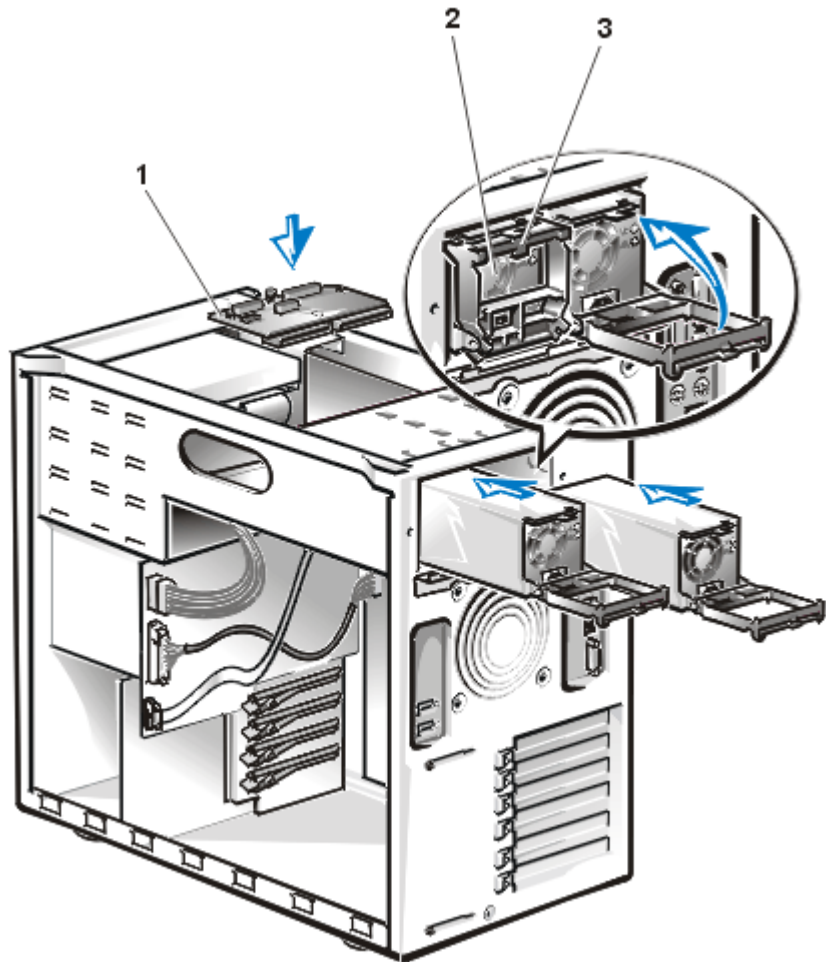

Figure B-3. Installing the PSDB and Dual Power Supplies

-
- 1 PSDB
 - 2 Power supplies (2)
 - 3 Catch on power supply handle
-

9. Attach the 12-conductor cable labeled "PWR3" to connector P3 on the PSDB (see Figure B-4) and to connector POWER2 on the system board.

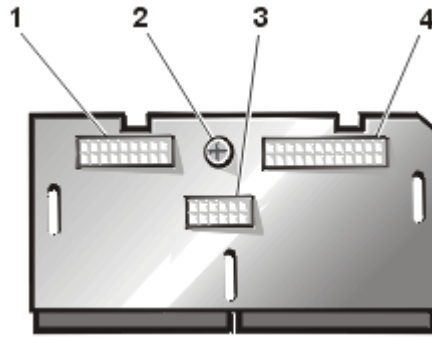

Figure B-4. Features on the PSDB

-
- 1 Power connector P2
 - 2 Thumbscrew
 - 3 Power connector P3
 - 4 Power connector P1
-
10. Attach the 24-conductor cable labeled "PWR1" to connector P1 on the PSDB and connector POWER1 on the system board.
 11. To attach the cable harness provided in the upgrade kit, perform the following steps:
 - a. Attach the 18-pin connector labeled "PWR2" to connector P2 on the PSDB.
 - b. Attach the 16-pin connector to the connector labeled "POWER" on the SCSI backplane board.
 - c. Connect the remaining connectors on the cable harness to the diskette drive, tape drive, or other drives in the external drive bays.
 12. Replace the top cover and secure it with the two screws.
 13. Replace the two computer covers.

Installing the Dual Power Supplies

To install the dual power supplies, perform the following steps.

NOTICE: The power supplies are heavy. Support them with both hands when you install or remove them.

1. Using your thumb and index finger, squeeze the catch in the middle of the power supply handle (see Figure B-3).
2. Rotate the handle downward.

NOTICE: Do not use excessive force when sliding the power supply into the chassis.

3. Slide the power supply into the chassis (see Figure B-3).
4. Rotate the power supply handle to the closed position (see Figure B-3).

For better leverage, press against the upper corners of the handle.

NOTE: The power supply will not function until the handle is closed.



5. Repeat steps 1 through 4 to install the second power supply.
6. Connect the AC power cable to the power supplies and to the electrical outlet.
7. Make sure that the AC power cable passes through the plastic strain-relief clip on the system back panel.

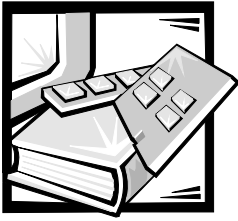

Abbreviations and Acronyms

The following list defines or identifies technical terms, abbreviations, and acronyms used in Dell™ user documents.

NOTE: Unless otherwise specified, these definitions may not apply to operating systems other than Microsoft® Windows® 95 and Windows NT®.

A

ampere(s)

AC

alternating current

ACPI

Advanced Configuration and Power Interface

ADC

analog-to-digital converter

ADI

Autodesk Device Interface

AI

artificial intelligence

ANSI

American National Standards Institute

APIC

Advanced Peripheral Interrupt Controller

ASCII

American Standard Code for Information Interchange

ASIC

application-specific integrated circuit

B

BASIC

Beginner's All-Purpose Symbolic Instruction Code

BBS

bulletin board service

BIOS

basic input/output system

bpi

bits per inch

bps

bits per second

BTU

British thermal unit

C

Celsius

CCFT

cold cathode fluorescent tube

CD

compact disc

CD-ROM

compact disc read-only memory

CGA

color graphics adapter

cm

centimeter(s)

CMOS

complementary metal-oxide semiconductor

C.O.D.

collect on delivery

cpi

characters per inch

cpl

characters per line

CPU

central processing unit

DAC

digital-to-analog converter

DASH

Dell Advanced SCSI Host

DAT

digital audio tape

dB

decibel(s)

dBA

adjusted decibel(s)

DC

direct current

DIMM

dual in-line memory module

DIN

Deutsche Industrie Norm

DIP

dual in-line package

DMA

direct memory access

DOC

Department of Communications (in Canada)

dpi

dots per inch

DRAC

Dell Remote Assistant Card

DRAM

dynamic random-access memory

DS/DD

double-sided double-density

DS/HD

double-sided high-density

DSA

Dell SCSI Array

ECC

error checking and correction

EDO

extended-data out

EGA

enhanced graphics adapter

EIDE

enhanced integrated drive electronics

EMI

electromagnetic interference

EMM

expanded memory manager

EMS

Expanded Memory Specification

EPP

Enhanced Parallel Port

EPROM

erasable programmable read-only memory

ESD

electrostatic discharge

ESDI

enhanced small-device interface

ESM

embedded server management

F

Fahrenheit

FAT

file allocation table

FCC

Federal Communications Commission

FIFO

first-in first-out

ft

feet

g

gram(s)

G

gravities

GB

gigabyte(s)

GUI

graphical user interface

h

hexadecimal

HIP

Hardware Instrumentation Package

HMA

high memory area

HPFS

High Performance File System

Hz

hertz

I/O

input/output

ICBM

inter-chassis management bus

ID

identification

IDE

integrated drive electronics

IRQ

interrupt request

ISA

Industry-Standard Architecture

JEIDA

Japanese Electronic Industry Development Association

K

kilo- (1024)

KB

kilobyte(s)

KB/sec

kilobyte(s) per second

Kb

kilobit(s)

Kbps

kilobit(s) per second

kg

kilogram(s)

kHz

kilohertz

LAN

local area network

lb

pound(s)

LCD

liquid crystal display

LED

light-emitting diode

LIF

low insertion force

LN

load number

lpi

lines per inch

LVD

low voltage differential

m

meter(s)

<i>mA</i> milliampere(s)	<i>NMI</i> nonmaskable interrupt
<i>mAh</i> milliampere-hour(s)	<i>NNM</i> Network Node Manager
<i>MB</i> megabyte(s)	<i>ns</i> nanosecond(s)
<i>Mb</i> megabit(s)	<i>NTFS</i> NT File System
<i>Mbps</i> megabit(s) per second	<i>NVRAM</i> nonvolatile random-access memory
<i>MBR</i> master boot record	<i>OS/2®</i> Operating System/2
<i>MDA</i> monochrome display adapter	<i>OTP</i> one-time programmable
<i>MGA</i> monochrome graphics adapter	<i>PAL</i> programmable array logic
<i>MHz</i> megahertz	<i>PCI</i> Peripheral Component Interconnect
<i>MMX™</i> MultiMedia eXtensions	<i>PCMCIA</i> Personal Computer Memory Card International Association
<i>mm</i> millimeter(s)	<i>PGA</i> pin grid array
<i>ms</i> millisecond(s)	<i>POST</i> power-on self-test
<i>MS-DOS®</i> Microsoft® Disk Operating System	<i>ppm</i> pages per minute
<i>MTBF</i> mean time between failures	<i>PQFP</i> plastic quad flat pack
<i>mV</i> millivolt(s)	<i>PSDB</i> power-supply distribution board
<i>NIC</i> network interface controller	<i>PS/2</i> Personal System/2
<i>NiCad</i> nickel cadmium	<i>PVC</i> polyvinyl chloride
<i>NiMH</i> nickel-metal hydride	<i>QIC</i> quarter-inch cartridge

RAID

redundant arrays of independent disks

RAM

random-access memory

RAMDAC

random-access memory digital-to-analog converter

RCU

Resource Configuration Utility

REN

ringer equivalence number

RFI

radio frequency interference

RGB

red/green/blue

ROM

read-only memory

rpm

revolutions per minute

RTC

real-time clock

SCA

Single Controller Architecture

SCSI

small computer system interface

SDS

Scalable Disk System

sec

second(s)

SEC

single-edge contact

SDRAM

synchronous dynamic random-access memory

SIMM

single in-line memory module

SMB

server management bus

SNMP

Simple Network Management Protocol

SRAM

static random-access memory

SSU

system setup utility

SVGA

super video graphics array

TFT

thin film transistor

tpi

tracks per inch

TSR

terminate-and-stay-resident

UMB

upper memory block

UPS

uninterruptible power supply

USOC

Universal Service Ordering Code

V

volt(s)

VAC

volt(s) alternating current

VDC

volt(s) direct current

VESA®

Video Electronics Standards Association

VGA

video graphics array

VLSI

very-large-scale integration

VRAM

video random-access memory

W

watt(s)

WH

watt-hour(s)

X**XMM**

extended memory manager

XMS

eXtended Memory Specification

Z**ZIF**

zero insertion force



Printed in the U.S.A.

DELL

DELL™

Dell™ PowerEdge™ 2

INSTALLATION TROUBLESHOOTING GUIDE

DELL™

Dell PowerEdge 2400 Systems Installation and Troubleshooting Guide



* 9 4 3 7 P *

P/N 9437P Rev. A01

DELL

DELL™

Dell™ PowerEdge™ 2

**INSTALLATION
TROUBLESHOOTING
GUIDE**

Dell PowerEdge 2400 Systems Installation and Troubleshooting Guide



Printed in Ireland.

DELL™



P/N 9437P Rev. A01

DELL

DELL™

Printed in Malaysia.

Dell™ PowerEdge™ 2400

**INSTALLATION
TROUBLESHOOTING
GUIDE**

Dell PowerEdge 2400 Systems Installation and Troubleshooting Guide

DELL™



* 9 4 3 7 P *

P/N 9437P Rev. A01

Dell Information Development

Postscript Imaging and Printing Specs

JOB TITLE:	Dell PowerEdge 2400 Systems Installation and Troubleshooting Guide (s:\systems iguana\trw\paper_I&TVA01)
LANGUAGES:	English
PART NUMBER:	9437P A01 Checked in EMPACT: Currently at A00
PREPARED BY:	Gloria Salinas Kim Tomlin
CONTACT:	Cathy Brown 512-723-9330
EMAIL ADDRESS:	Cathy_Brown@dell.com
VENDOR:	EMF/Copyright/Apcc/CCC
DATE:	10/06/99 12/20/00 - create BP cover and send entire book to BCC

COMPUTER SOURCE:	Dell PC
APPLICATION SOFTWARE:	FrameMaker Version 5.5.2
POSTSCRIPT FILES:	Yes/Yes/Yes/Yes
POSTSCRIPT DRIVER USED:	Linotronic 330
COLOR SEPARATED FILES:	No
COMPRESSED & TESTED:	Yes/Yes/Yes/Yes
PAGE SIZE:	7.5 x 9 inches
PAGE ORIENTATION:	Portrait
LINE SCREEN:	133 lpi
TRANSPORT MEDIA:	FTP/FTP/FTP/FTP
HALFTONES/SCREENS/	No
DUOTONES:	No
COLOR(S):	Cover - Black; Magenta PMS 375; Cyan PMS 3005 Text - Black
COLOR MARKUP PROVIDED:	No

Continued on Back

**For questions or problems with files contact:
Donna Moore - Graphic Development
Dell Computer Corporation (512) 728-3439**

Dell Information Development

Postscript Imaging and Printing Specs

FILE NAME(S) & PAGE COUNT:	Section	Filename	Page Count	Page Number
	Title Page	9437Ptp1.ps	2	title and copyright
	Safety	9437Psi1.ps	10	v - xiv
	Preface	9437Ppr1.ps	4	xv - xviii
	TOC	9437Ptc1.ps	6	xix - xxiv
	Chapter 1	9437Pc11.ps	2	1-1 - 1-2
	Chapter 2	9437Pc21.ps	8	2-1 - 2-8
	Chapter 3	9437Pc31.ps	18	3-1 - 3-18
	Chapter 4	9437Pc41.ps	4	4-1 - 4-4
	Chapter 5	9437Pc51.ps	6	5-1 - 5-6
	Chapter 6	9437Pc61.ps	8	6-1 - 6-8
	Chapter 7	9437Pc71.ps	30	7-1 - 7-30
	Chapter 8	9437Pc81.ps	20	8-1 - 8-20
	Chapter 9	9437Pc91.ps	8	9-1 - 9-8
	Chapter 10	9437P101.ps	10	10-1 - 10-10
	Chapter 11	9437P111.ps	20	11-1 - 11-20
	Appendix A	9437Paa1.ps	6	A-1 - A-6
	Appendix B	9437Pab1.ps	6	B-1 - B-6
	Abbr.& Acronyms	9437Paz1.ps	6	1-6
	Full Cover		2	(incl. blank inside)
	American	9437Pam1.ps		
	OR	OR		
	European	9437Pem1.ps		
	OR	OR		
	APCC	9437Pap1.ps		
	OR	Or		
	CCC	9437Pcc1.ps		
	OR	or		
	BCC	9437Pbp1.ps		
TOTAL PAGE COUNT:			176	

SPECIAL INSTRUCTIONS:	Add blank pages needed to complete signatures.
------------------------------	--

**For questions or problems with files contact:
Donna Moore - Graphic Development
Dell Computer Corporation (512) 728-3439**